

NEWS

03.2024

womix
Comfort Controls



ENERGY-SAVING CENTRAL HEATING EQUIPMENT



mixing valves



hydraulic separators



boiler room building systems

www.womix.pl

Womix Sportowa 31 89-200 Szubin
phone: +48 52 382 44 50
mobile: 570 108 498

Stainless steel manifold CS-Rot

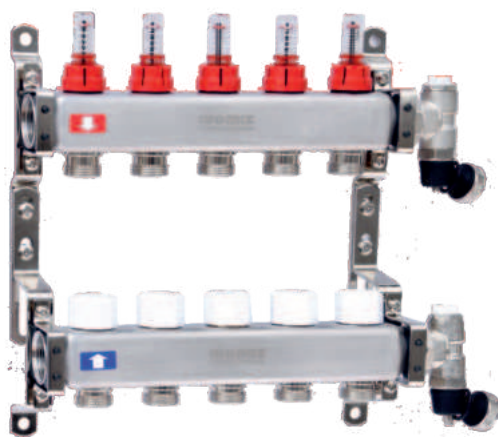

CS-Rot manifolds are made of SS304 stainless steel and are used to connect a specific number of heating or cooling circuits with individual flow regulation/cut-off. In addition, they enable the connection of a mixing and pump group in order to obtain the design temperature for underfloor heating and maintain appropriate operating parameters of the installation by independently powering each heating circuit. They are available with Taconova rotameters 0-5 l/min or 0-2.5 l/min. They are equipped with chrome-plated handles with adjustable spacing and a vent and drain group with an additional mounting nut.

Technical data:

Material:	SS304 non-magnetic stainless steel
Medium:	water or a solution of water and glycol up to 30%
Max. temperature:	70 °C
Max. working pressure:	6 bar
Connections:	boiler side 1" F, installation side 3/4" M
Insert connection:	M30x1.5

Taconova rotameter

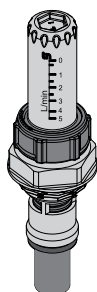
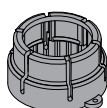

Manifold CS-Rot02 --> rotameter 0 - 2.5 l/min

Manifold CS-Rot05 --> rotameter 0 - 5 l/min

- Accurate and fast flow regulation, without graphs, tables or measuring devices,
- Flow measured directly in l/min,
- The last set setting can be easily recreated thanks to the locking screw,
- The regulating cap can be sealed,
- Regulating valve with the option of cutting off the flow,
- Removable sight glass,
- Vertical or horizontal installation allowed,

Type	Quantity section	L [mm]	CS-Rot05 Rotameter 0-5 l/min	CS-Rot02 Rotameter 0-2,5 l/min
Stainless steel manifold for underfloor heating CS-Rot 2F	2	130	205002	225002
Stainless steel manifold for underfloor heating CS-Rot 3F	3	180	205003	225003
Stainless steel manifold for underfloor heating CS-Rot 4F	4	230	205004	225004
Stainless steel manifold for underfloor heating CS-Rot 5F	5	280	205005	225005
Stainless steel manifold for underfloor heating CS-Rot 6F	6	330	205006	225006
Stainless steel manifold for underfloor heating CS-Rot 7F	7	380	205007	225007
Stainless steel manifold for underfloor heating CS-Rot 8F	8	430	205008	225008
Stainless steel manifold for underfloor heating CS-Rot 9F	9	480	205009	225009
Stainless steel manifold for underfloor heating CS-Rot 10F	10	530	205010	225010
Stainless steel manifold for underfloor heating CS-Rot 11F	11	580	205011	225011
Stainless steel manifold for underfloor heating CS-Rot 12F	12	630	205012	225012



Thermoelectric actuator MP VM200

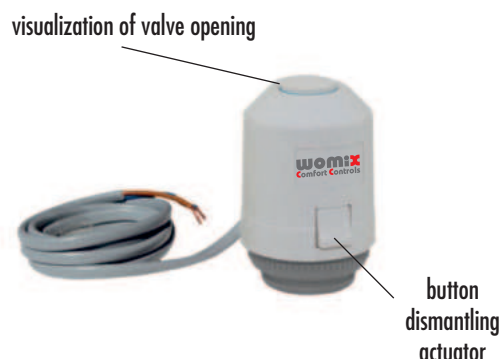

The MP VM200 thermoelectric actuator is a drive for opening and closing valves on underfloor heating manifolds. The set includes an adapter that allows the device to be mounted on thermostatic valves in CS-Rot manifolds. The adapter allows for quick installation of the actuator only by pressing it and subsequent disassembly of the actuator only by using the disassembly button. The actuator is in the normally closed position, after applying voltage it opens the valve flow.

Technical data:

Actuator version:	normally closed
Voltage:	230 V AC, +10%...-10%, 50/60 Hz
Working power:	2W
Valve opening time:	3 minutes
Actuator stroke:	4mm
Actuator power:	200N

Type	Catalog number
Thermoelectric actuator MP VM200 with adapter for CS-Rot manifolds	401080

Set of straight ball valves with thermometers



The set includes 2 straight ball valves in blue and red with thermometers, 1" gasket connection

Technical data:

Thermometers:	scale 0-80 °C
Connections:	1"

Type	Catalog number
Set of 2 straight ball valves with a thermometer and a gasket for connection with CS manifolds	210035

Set of straight ball valves with thermometers



SL series actuators are compact and solid design. Under the plastic housing are located: transmission with a maximum torque of 10 Nm actuator SL 10, a synchronous motor, two limit switches. The SL actuator factory is equipped with a 1.5 meter cable 3 x 0.75.

Technical data:

Voltage	230V AC 50-60HZ,
Consumer Power Max	5W
Running time	60sec, 120sec (depending on the model)
Torque	10Nm
Control signal	3 point SPDT,

Type	Voltage	Rotation time	Catalog number
Actuator SL 10 - 230/60s	230 V AC	60 s	415000
Actuator SL 10 - 230/120s	230 V AC	120 s	415001



Anti-freeze valve WFV



The anti-freeze valve installed in the heat pump installation allows for slow release of the medium when the medium temperature drops below 3 °C. This prevents ice from forming in the installation, protecting its components from damage. It is recommended to install 2 anti-freeze valves in the installation.

Technical data:

Material:	brass
Max. static pressure:	10 bar (PN 10)
Max. medium temperature:	90°C
Ambient temperature range:	-30°C to + 50°C
Temp. medium starting opening:	+3°C
Temp. closing medium:	+4°C
Accuracy:	+/-1°C
Connections:	1" M for 601561 1 1/4" M for 601562

Possibility to control the anti-vacuum valve.

Possibility to check the cleaning cartridge and replace the sensor.

Dimensional diagram

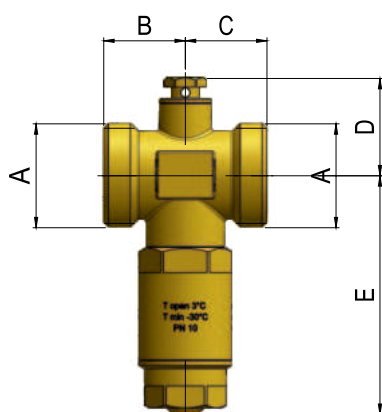

P[bar]	Outside and fluid temperature [°C]	Q[L/min]
1	0,5	6
0,2	0,5	2,7
0,05	0,5	1,3

A	B	C	D	E
G1"	26	26	31	76
G 1 1/4"	29,5	29,5	33	78

Type	Kvs	Catalog number
Anti-freeze valve WFV-25M, PN 10, kvs 68	68	200611
Anti-freeze valve WFV-32M, PN 10, kvs 90	90	200612



Zone 3-way valves WZP3



3-way zone valves of the WZP3 series are intended for heating and cooling systems. They are used in installations where it is required to use an element that switches the flow directions of the medium. The actuator is mounted on the valve with a clip, which facilitates assembly and does not require any additional tools. The actuator is equipped with an anti-blocking function. If the motor is blocked, it reverses its direction of operation. Thanks to this, the actuator is protected against damage, which significantly increases its service life. The valve scale shows the current position of the valve, and the compact dimensions allow it to be used even in small rooms.

Assembly diagram

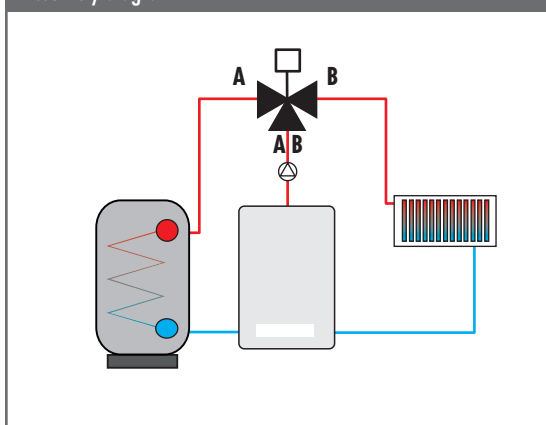

Possible mounting positions

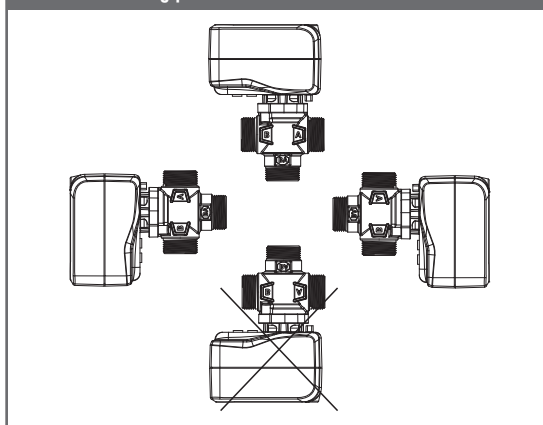

Technical data:

Connections:	WZP3-20M - 3/4" M WZP3-25M - 1" M. WZP3-32M - 1 1/4" M.
Kvs:	8 m ³ /h WZP3-25M 13 m ³ /h WZP3-32M
Voltage/Power:	230V AC, 50 Hz, 7VA
Control signal:	2-point SPST
Protection class:	II, IP44
Position indicator:	on top of cover
Maximum Torque:	5 Nm
Cable :	3 x 0,75 mm ² , 1m
Rotation time and angle:	8s/60°
Ambient temperature:	0°C..+55°C
Certificate:	CE, ROHS
Nominal pressure:	PN10
Medium:	water, glycol < 50%, min. +5°C, max. +80°C
Media temperature:	min. +5°C, max. +80°C
Leakage (Δ p=1 bar):	0,1% kvs
Max. diff. pressure:	1 bar
Materials:	brass, PPS, PTFE
Sealing ring:	PA 66+ rubber

Type	Kvs	Voltage	Rotation time	Catalog number
Zone 3-way valve WZP3-20M	8	230	8 s	601071
Zone 3-way valve WZP3-25M	8	230	8 s	601072

DHW safety group 6 bar



DHW safety group is an important element of the hot water installation, whose main task is to protect the installation against the increase in pressure caused by the increase in water temperature in the system. It is intended for installation in home heating systems. The beam is equipped with a 6 bar safety valve, a pressure gauge and a set of mounting pins. Additionally, in the lower part of the beam there are connections for the expansion vessel and the safety beam supply.

Technical data:

Material:	brass
Maximum operating temperature:	95°C
Max. working pressure:	8 bar
Safety valve opening pressure:	6 bar
Vessel connection:	3/4" GW
Installation connection:	3/4"
Medium:	water/glycol

Type	Catalog number
DHW safety group 6 bar, with equipment	200611
DHW safety group 6 bar, with equipment, with automatic 3/4" quick coupling	200612

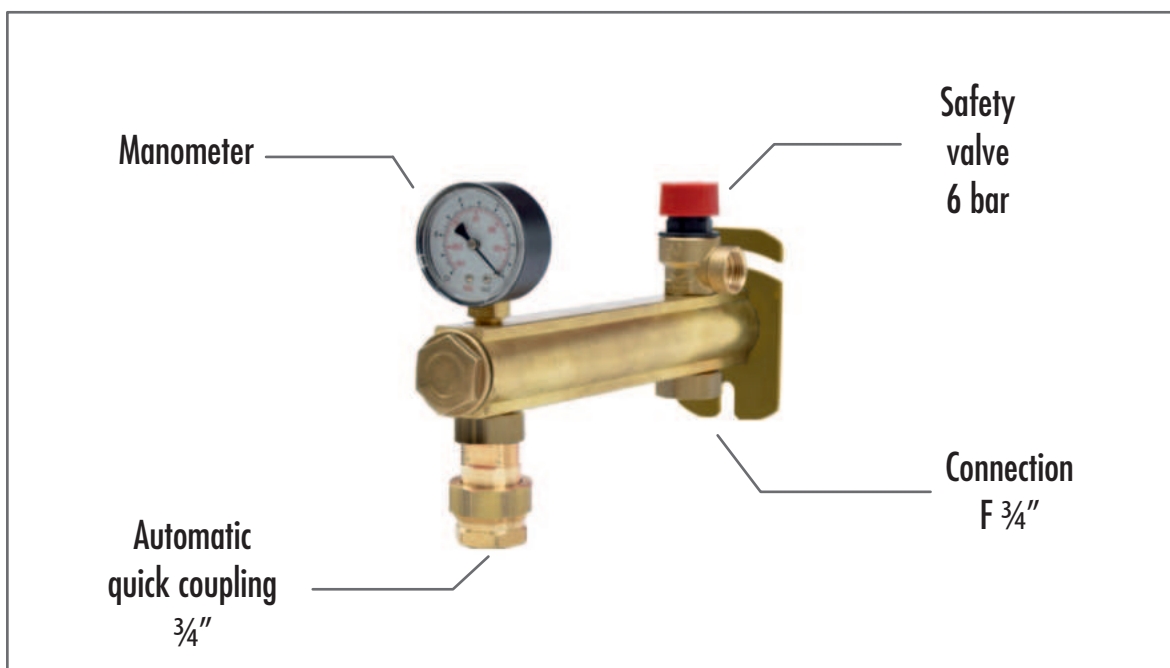

Safety group INOX C.H. 3 bar



Central heating safety group is an important element of the central heating system, whose main task is to protect the installation against pressure increases caused by the increase in water temperature in the system. It is intended for installation in home heating systems. The beam is equipped with an automatic air vent with a stop valve, a 3 bar safety valve, a pressure gauge and a set of mounting pins. Additionally, in the lower part of the beam there are connections for the expansion vessel and the boiler power supply.

Technical data:

Material:	stainless steel
Maximum operating temperature:	95°C
Max. working pressure:	6 bar
Safety valve opening pressure:	3 bar
Vessel connection:	¾" F / ¾" F quick connector
Installation connection:	¾"
Medium:	water/glycol

Type	Catalog number
Safety group INOX for central heating 3 bar, with equipment	200621
Safety group INOX for central heating 3 bar, with equipment, with automatic quick coupler ¾"	200622

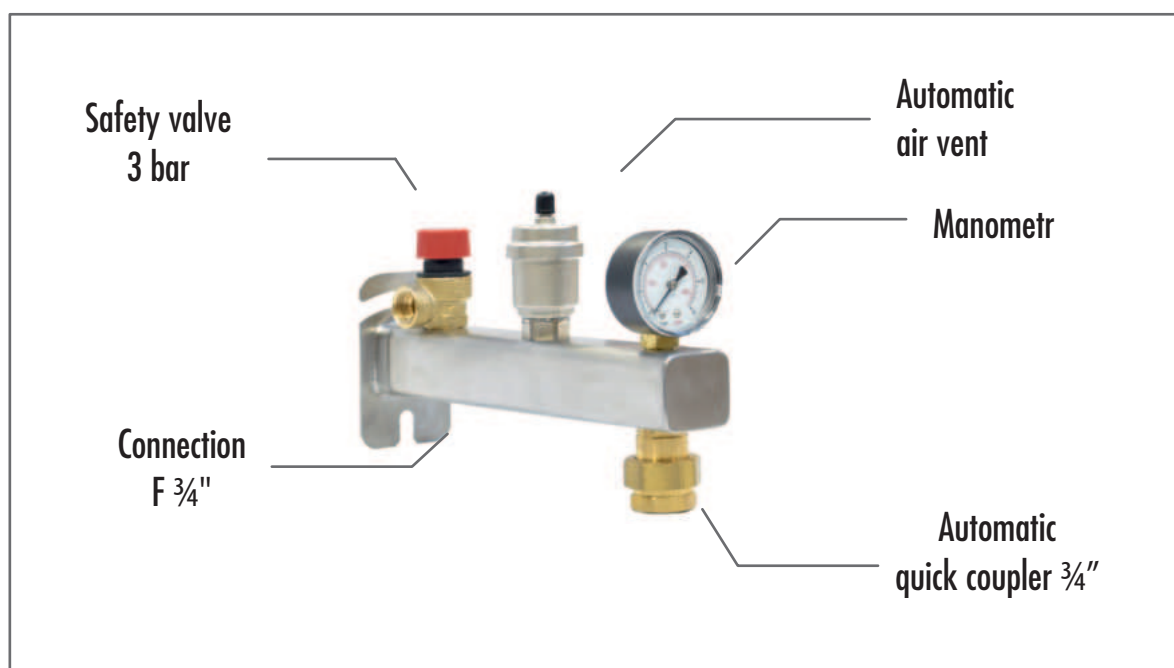

Safety group INOX for domestic hot water 6 bar



Safety group DHW is an important element of the hot water installation, whose main task is to protect the installation against the increase in pressure caused by the increase in water temperature in the system. It is intended for installation in home heating systems. The beam is equipped with a 6 bar safety valve, a pressure gauge and a set of mounting pins. Additionally, in the lower part of the beam there are connections for the expansion vessel and the power supply from the safety beam.

Technical data:

Material:	stainless steel
Maximum operating temperature:	95°C
Max. working pressure:	8 bar
Safety valve opening pressure:	6 bar
Vessel connection:	3/4" GW
Installation connection:	3/4"
Medium:	water/glycol

Type	Catalog number
Safety group INOX for domestic hot water, 6 bar, with equipment	200625
Safety group INOX for domestic hot water, 6 bar, with equipment, with automatic quick coupler 3/4"	200626

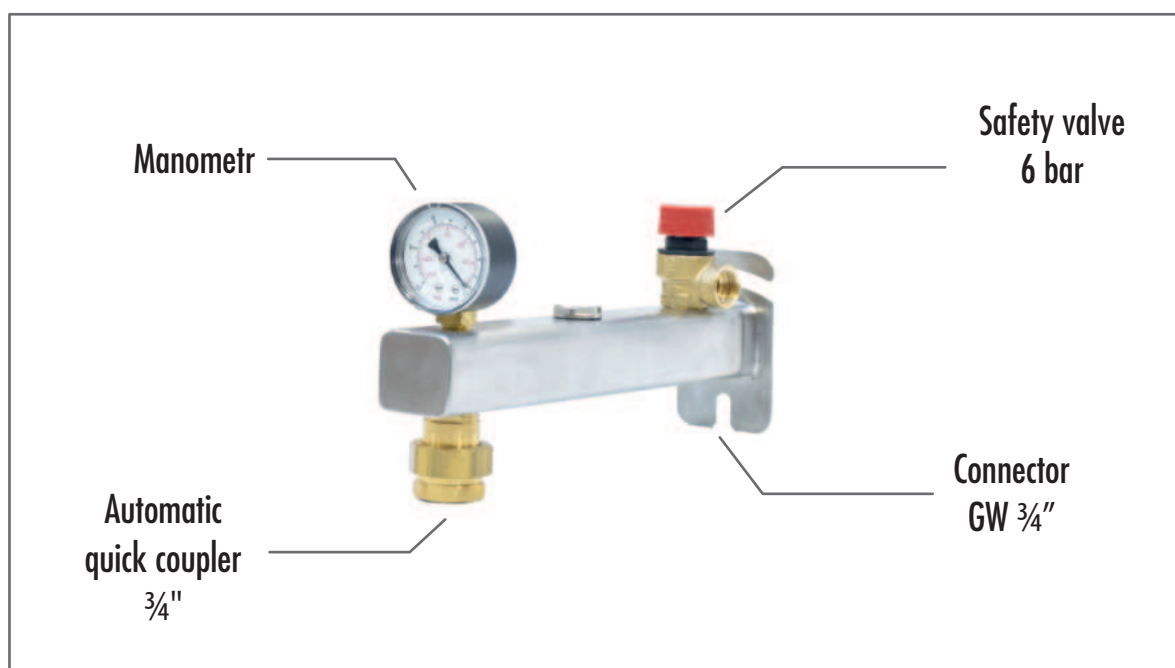

Safety group 3 bar



Central heating safety group is an important element of the central heating system, whose main task is to protect the system against pressure increase caused by the increase in water temperature in the system. It is designed for installation in home heating systems. The beam is equipped with an automatic air vent with a foot valve, a 3 bar safety valve, a pressure gauge and a set of mounting pins. In addition, in the lower part of the beam, there are connections to the expansion vessel and the power supply from the boiler.

Technical data:

Material:	steel
Maximum operating temperature:	95°C
working pressure:	6 bar
Safety valve opening pressure:	3 bar
Vessel connection:	3/4" internal thread / quick coupling 3/4" internal thread
Installation connection:	3/4"
Medium:	water/glycol

Type	Catalog number
Safety group 3 bar, equipment	200601
Safety group 3 bar, equipment, with automatic quick coupler 3/4"	200602

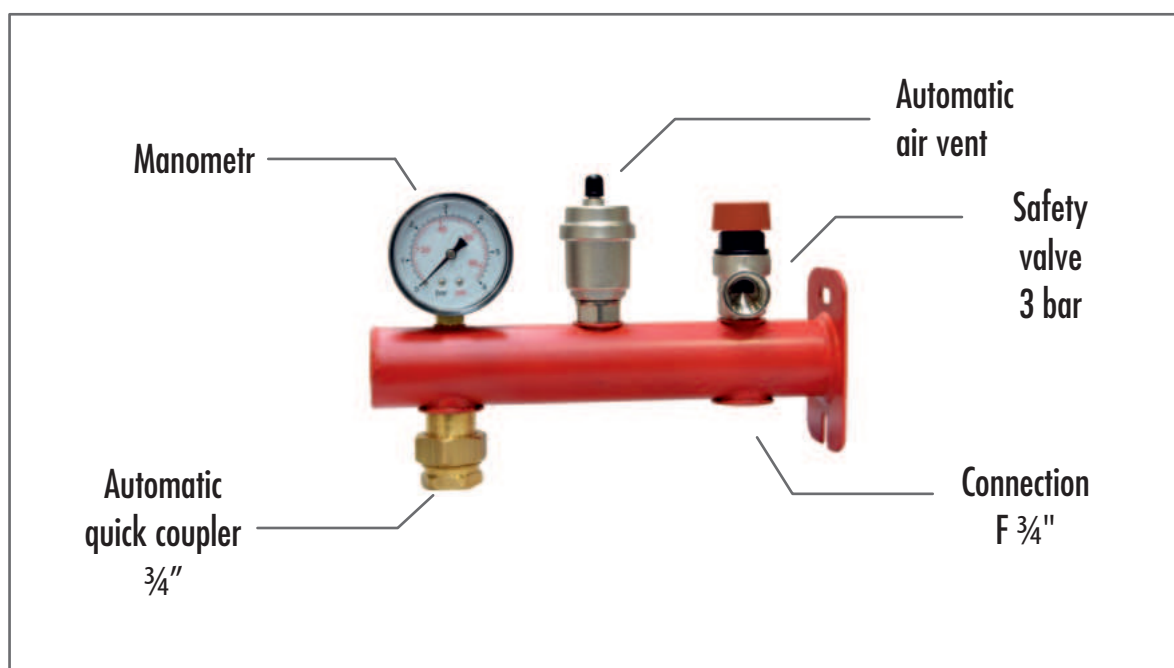

Basket strainer FMK



The FMK basket strainer is a device designed to capture solid pollution transmitted by water in central heating installations, heating networks and heat nodes. Their use allows the proper operation of heat exchangers, pumps, boilers and other system devices, preventing the deposition of impurities that remain in the filter basket and are easy to remove. Cleansing the medium stream is a process of mechanical separation of solid bodies (e.g. gravel, particles from corrosion of pipes) in a filter element, which is a removable basket. The basket is made of perforated stainless steel and 500 µm filter mesh. The body is made depending on the model of powder -painted or galvanized steel. In addition, the device occurs in variants with or without insulation. The basket strainer is equipped with a manual vent and a drain valve. In addition, to ensure the catching of ferromagnetic impurities, the device can be equipped with a magnetic insert.

Technical data:

Material:	Painted/galvanized steel (depending on the model)
Maximum pressure:	6 bar
Maximum operating temperature:	110 ° C
Filter insert:	500 µm
Pressure norm of collars:	PN 16
Flow:	6-30 m ³ /h (depending on the model)
Isulation:	EPP black/none (depending on the model)

Type	Catalog number
Basket strainer FMK 150 - DN 50 with additional equipment, without insulation, painted	609141
Basket strainer FMK 150 - DN 65 with additional equipment, without insulation, painted	609142
Basket strainer FMK 250 - DN 80 with additional equipment, without insulation, painted	609143
Basket strainer FMK 300 - DN 100 with additional equipment, without insulation, painted	609144
Basket strainer FMK 300 - DN 125 with additional equipment, without insulation, painted	609145
Type	Catalog number
Basket strainer FMKo 150 - DN 50 with additional equipment, without insulation, galvanized	609151
Basket strainer FMKo 150 - DN 65 with additional equipment, without insulation, galvanized	609152
Basket strainer FMKo 250 - DN 80 with additional equipment, without insulation, galvanized	609153
Basket strainer FMKo 300 - DN 100 with additional equipment, without insulation, galvanized	609154
Basket strainer FMKo 300 - DN 125 with additional equipment, without insulation, galvanized	609155
Type	Catalog number
Basket strainer FMK+ 150 - DN 50 with additional equipment, with insulation, painted	609241
Basket strainer FMK+ 150 - DN 65 with additional equipment, with insulation, painted	609242
Basket strainer FMK+ 250 - DN 80 with additional equipment, with insulation, painted	609243
Basket strainer FMK+ 300 - DN 100 with additional equipment, with insulation, painted	609244
Basket strainer FMK+ 300 - DN 125 with additional equipment, with insulation, painted	609245
Type	Catalog number
Basket strainer FMKo+ 150 - DN 50 with additional equipment, with insulation, galvanized	609251
Basket strainer FMKo+ 150 - DN 65 with additional equipment, with insulation, galvanized	609252
Basket strainer FMKo+ 250 - DN 80 with additional equipment, with insulation, galvanized	609253
Basket strainer FMKo+ 300 - DN 100 with additional equipment, with insulation, galvanized	609254
Basket strainer FMKo+ 300 - DN 125 with additional equipment, with insulation, galvanized	609255



Connector distance for FMK



The distance connector helps in mounting the basket strainers in pump groups.

Type	Catalog number
Connector distance DN 50 (L-350mm) for FMK 150 - DN 50 with 4 mounting screws and a gasket EPDM DN 65	699061
Connector distance DN 65 (L-350mm) for FMK 150 - DN 65 with 4 mounting screws and a gasket EPDM DN 65	699062
Connector distance DN 80 (L-510mm) for FMK 250 - DN 80 with 4 mounting screws and a gasket EPDM DN 80	699063
Connector distance DN 100 (L-510mm) for FMK 300 - DN 100 with 4 mounting screws and a gasket EPDM DN 100	699064
Connector distance DN 125 (L-510mm) for FMK 300 - DN 125 with 4 mounting screws and a gasket EPDM DN 125	699065

Magnetic insert for FMK



The magnetic insert is used to capture metal particles, preventing impurities in the installation.

Type	Catalog number
Magnetic insert 1/2" for basket strainer FMK 150 - DN 50, DN 65	607260
Magnetic insert 3/4" for basket strainer FMK 250 - DN 80	607261
Magnetic insert 1" for basket strainer FMK 300 - DN 100, DN 125	607262

Example of application

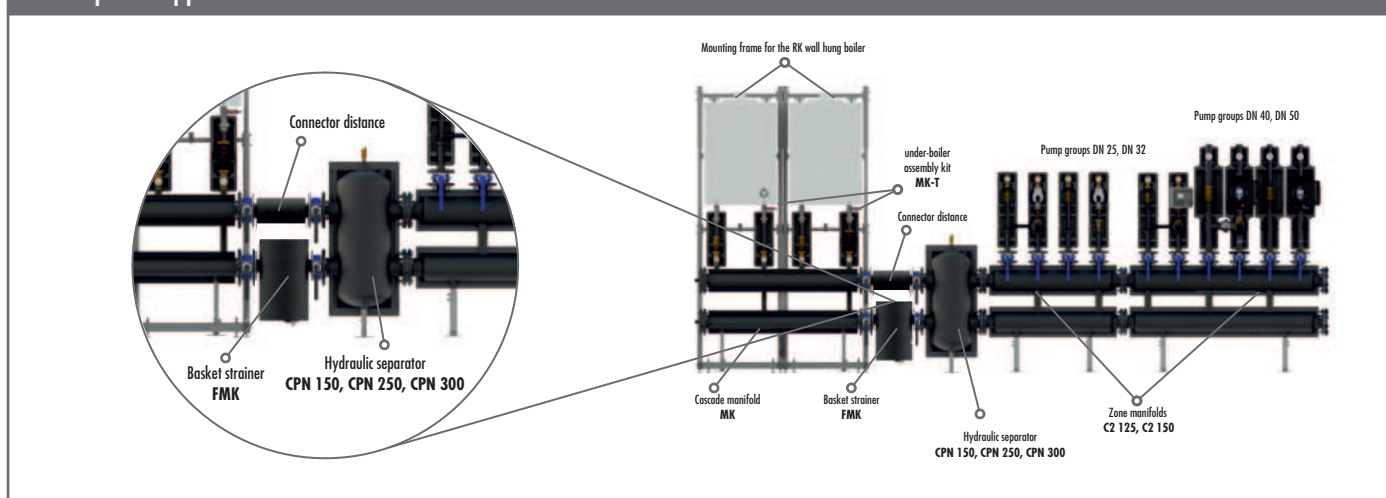

In order to facilitate the periodic cleaning of the installation, it is recommended to mount the shut-off valves before and for basket strainer.



Butterfly valves WX and WXS



Butterfly valve WX are designed for shutting off and regulating the flow of cold and hot water. They are used in heating systems, sewage systems and tap water systems (with a stainless steel disc). Short construction, low pressure losses and simple assembly allow for use wherever it is impossible to install a ball valve. The dampers are available in diameters DN50 - DN 300 with a cast iron disc or a stainless steel disc.

Technical data:

Body:	gray cast iron GG25 (for diameters DN250 and DN300 ductile iron)
Disc:	GGG40 ductile iron or AISI 316 stainless steel
Maximum pressure:	16 bar
Temperature range:	-20 °C to 120 °C

Type	DN	Catalog number
Butterfly valve with handle WX50 , with a cast iron disc	50	005061
Butterfly valve with handle WX65 , with a cast iron disc	65	005062
Butterfly valve with handle WX80 , with a cast iron disc	80	005063
Butterfly valve with handle WX100 , with a cast iron disc	100	005064
Butterfly valve with handle WX125 , with a cast iron disc	125	005065
Butterfly valve with handle WX150 , with a cast iron disc	150	005066
Butterfly valve with handle WX200 , with a cast iron disc	200	005067
Butterfly valve with gearbox WX250 , with a cast iron disc	250	005068
Butterfly valve with gearbox WX300 , with a cast iron disc	300	005069
Type	DN	Catalog number
Butterfly valve with handle WX50S , with a stainless steel disc	50	005081
Butterfly valve with handle WX65S , with a stainless steel disc	65	005082
Butterfly valve with handle WX80S , with a stainless steel disc	80	005083
Butterfly valve with handle WX100S , with a stainless steel disc	100	005084
Butterfly valve with handle WX125S , with a stainless steel disc	125	005085
Butterfly valve with handle WX150S , with a stainless steel disc	150	005086
Butterfly valve with handle WX200S , with a stainless steel disc	200	005087



Magnetic filter with strainer FM

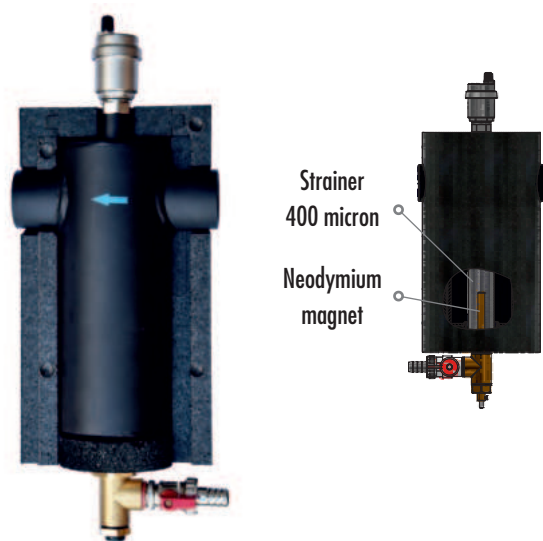

The **FM** magnetic filter is a device designed to trap solid pollutants carried by water in central heating installations, heating networks, heat centers, boiler rooms, as well as in glycol installations in air-conditioning systems. Their use allows for the proper operation of heat exchangers, pumps, boilers and other system devices, preventing the deposition of impurities that remain in the desilter and are easy to remove. Contrary to systems without a filter separator, the sedimentation of sludge and limescale effectively reduces the efficiency of devices operating in such conditions. This is especially important for heat exchangers.

Advantages of using a magnetic filter with strainer:

- securing and significantly reducing the risk of damage to the installation and its components,
- silencing the operation of the installation,
- exceptional simple removal of the separator contamination, removal of contamination without the need to shut down the installation.

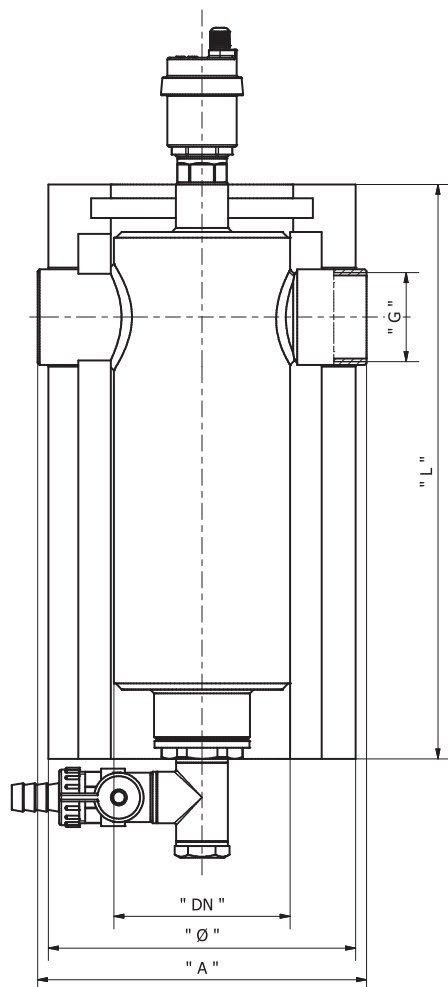

Type	Catalog number
Magnetic filter with strainer FM 65 - DN 25 with insulation, with equipment	611091
Magnetic filter with strainer FM 80 - DN 32 with insulation, with equipment	611092
Magnetic filter with strainer FM 100 - DN 40 with insulation, with equipment	611093
Magnetic filter with strainer FM 150 - DN 50 with insulation, with equipment	611094

	FM 65 - DN 25	FM 80 - DN 32	FM 100 - DN 40	FM 150 - DN 50
A	160	160	195	260
Ø	155	155	190	250
L	260	290	350	400
DN	65	80	100	150
G	1" F	1 1/4" F	1 1/2" F	2" F
Power	50 kW	80 kW	120 kW	180 kW



Heat pump or air conditioner WM stand / bracket



The stands (supports) WM II and WM III intended for heat pumps or air conditioners are made of steel. The stability of the stand has been increased by the use of adjustment fasteners on both sides. The design of the stand guarantees that it can be used with any heat pump or air conditioner. The brackets are equipped with vibration isolators to catch vibrations of the device and feet, together with a handle that allows the stand to be anchored. The bracket with the device should be placed on a permanently leveled base that can carry five times the weight of the device. Possible unevenness can be eliminated by a foot with an adjusting screw

Set contains:

- Steel elements of the stand
- Vibro-isolators with nuts
- Adjustable feet with the possibility of anchoring to the ground
- Mounting screws

Maximum load on the rack:

for WM II - 320kg
for WM III - 360 kg

Type	Catalog number
Stand / bracket for the heat pump or air conditioner WM II 42/92	610951
Stand / bracket for the heat pump or air conditioner WM II 52/92	610955
Stand / bracket for the heat pump or air conditioner WM II 52/135	610956
Stand / bracket for the heat pump or air conditioner WM III 42/135	610962
Stand / bracket for the heat pump or air conditioner WM III 52/135	610964

Dimensions:

WM II

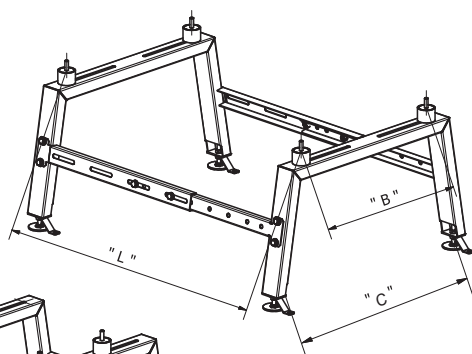

WM III

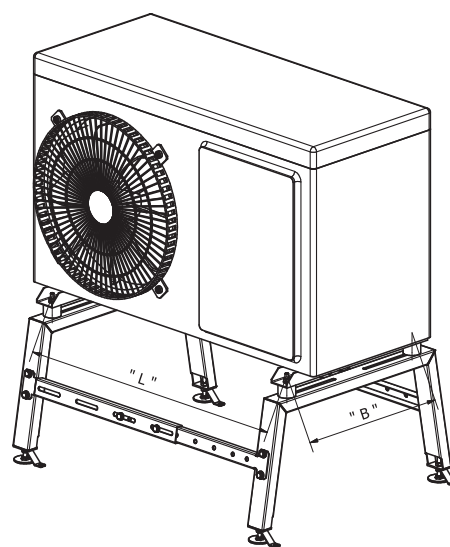
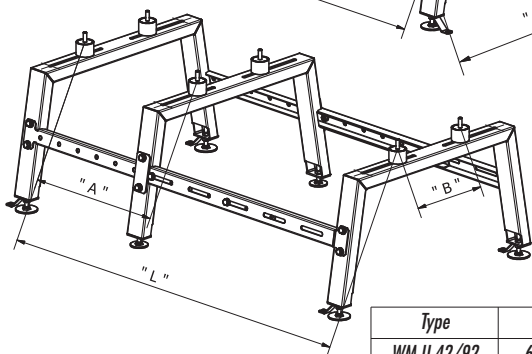

the height of the stands is min 350 mm - max 370 mm

If in doubt, the match of the WM stand to the device used please contact us by e-mail at export@womix.pl

Type	cod.	mounting width „B”	mounting width „C”	mounting length „L”	„A”
WM II 42/92	610951	min. 100 - max. 420 mm	600 mm	min. 500 - max. 920 mm	
WM II 52/92	610955	min. 140 - max. 520 mm	700 mm	min. 500 - max. 920 mm	
WM II 52/135	610956	min. 140 - max. 520 mm	700 mm	min. 830 - max. 1350 mm	
WM III 42/135	610962	min. 100 - max. 420 mm	600 mm	min. 830 - max. 1350 mm	min. 100 - max. 710mm
WM III 52/135	610964	min. 140 - max. 520 mm	700 mm	min. 830 - max. 1350 mm	min. 100 - max. 710mm



Two-zone accumulation hydraulic separator **DUO-ZONER**

Equipments:

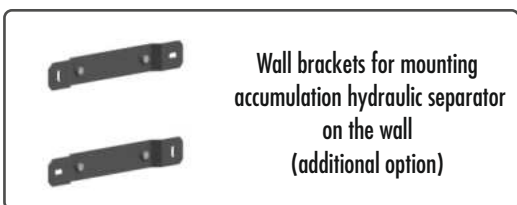
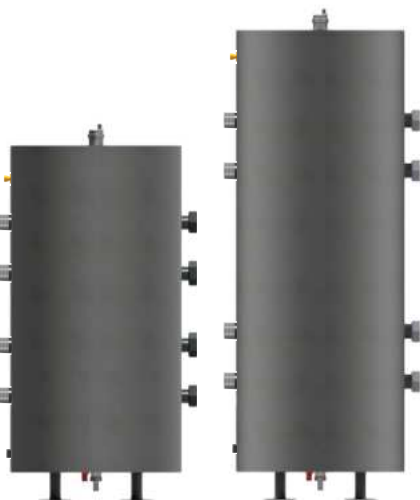
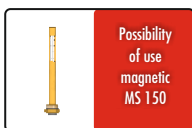
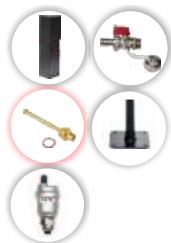

The two-zone accumulation hydraulic separator **DUO-ZONER** is made of steel. It works as a tank, hydraulic separator and zone manifold for two heating circuits. Its task is to facilitate the operation of the heat pump in order to meet the heat demand with optimal modulation and to cover the peak loads with the support of an auxiliary heat source. Appropriate placement of connections and a partition ensures proper liquid stratification and maintaining an appropriate difference between the two temperature levels. The diameter and spacing of the connections allow for direct connection of DN 25 pump groups in any configuration, giving the possibility to operate up to 2 heating circuits. They are available in two versions, a capacity of 45 L and 70 L, and each of them has the option of connecting 2 heat sources. An additional sleeve allows the use of a magnetic insert MI 150 - DN 15. The product includes insulation, automatic air vent, immersion sleeve for the temperature sensor, drain valve and mounting feet.

Technical data:

Total capacity:	45L or 70L (depending on the model)
Insulation:	EPP black 60 g/l
Pressure:	6 bar
Maximum temperature:	95 °C
Connection diameter:	
heat source side:	1" M
heating circuits side:	1 1/2" nut
Spacing of connections:	
side of heating circuits:	125mm

Type	Capacity [l]	Catalog number
Two-zone accumulation hydraulic separator DUO-ZONER 45	45	606790
Two-zone accumulation hydraulic separator DUO-ZONER 70	70	606791
Wall brackets for mounting on the wall		606799
Magnetic cartridge MS 150 - DN 15		607250

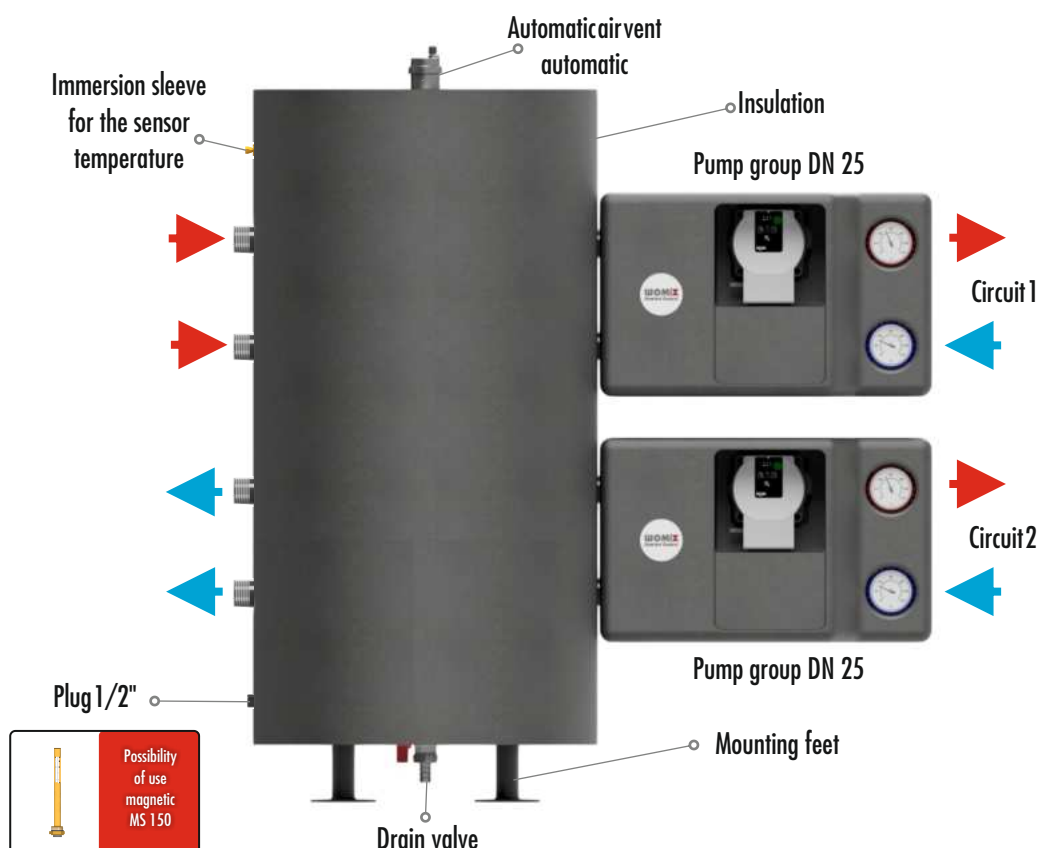

Possibility to connect groups pumps on either side by turning by 180°

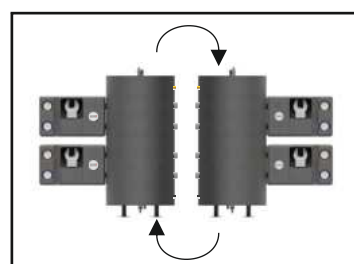

The system is designed to enable assembly pump groups on the wall

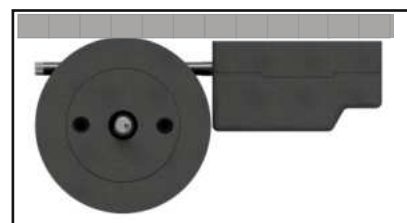

DUO-ZONER sets for two heating circuits with left and right connection

Set **DUO-ZONER L** (left sided)



DUO-ZONER 45 - 45 L
DUO-ZONER 70 - 70 L

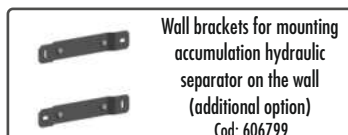

Set **DUO-ZONER P** (right sided)



Pump groups mounted on the left side of the two-zone accumulation hydraulic separator. Power supply to the pump groups on the right.

Connection of heat sources on the right side of the two-zone accumulation hydraulic separator.

Pump groups mounted on the right side of the two-zone accumulation hydraulic separator. Supply of the pump groups on the left side.

Connection of heat sources on the left side of the two-zone accumulation hydraulic separator. When ordering this type of set, the pump groups will be factory-delivered with the flow on the left side.

DUO-ZONER 1 set - a set of 2 heating circuits, including one with a rotary mixing valve and an electric actuator

DUO-ZONER 1L



DUO-ZONER 1P



Set 1P requires changing the supply side of the pump group to the left side



Set contains:

1. Two-zone accumulation hydraulic separator **DUO-ZONER 45** (Cod.:606890) or **DUO-ZONER 70** (Cod.:606891),
2. Pump group **SA 125 - DN 25**:
 - without pump (Cod.:606051),
 - with pump **Wilo Yonos Para 25/6** (Cod.:616054)
 - with pump **Grundfos UPM3S AUTO 25-60** (Cod.:616056)
 - with pump **DAB Evosta2** (Cod.:616057)
3. Pump group **SMT 125 - DN 25**:
 - without pump (Cod.:606081),
 - with pump **Wilo Yonos Para 25/6** (Cod.:616084)
 - with pump **Grundfos UPM3S AUTO 25-60** (Cod.:616086)
 - with pump **DAB Evosta2** (Cod.:616087)
4. Check valve (Cod.:606031),
5. Actuator **MP 10 - 230 / 140** with adapter nr **A 101**(Cod.:401011).



DUO-ZONER 2 set - a set of 2 heating circuits, including one with a thermostatic mixing valve

DUO-ZONER 2L



DUO-ZONER 2P

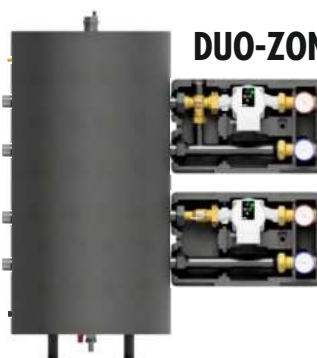

Set 2P requires changing the supply side of the pump group to the left side



Set contains:

- Two-zone accumulation hydraulic separator **DUO-ZONER 45** (Cod.:606890) or **DUO-ZONER 70** (Cod.:606891),
- Pump group **SA 125 - DN 25**:
 - without pump (Cod.:606051),
 - with pump **Wilo Yonos Para 25/6** (Cod.:616054)
 - with pump **Grundfos UPM3S AUTO 25-60** (Cod.:616056)
 - with pump **DAB Evosta2** (Cod.:616057)
- Pump group **SMTC1 125 - DN 25**:
 - without pump (Cod.:606071),
 - with pump **Wilo Yonos Para 25/6** (Cod.:616074)
 - with pump **Grundfos UPM3S AUTO 25-60** (Cod.:616076)
 - with pump **DAB Evosta2** (Cod.:616077)
- Check valve (Cod.:606031),

DUO-ZONER 3 set - set of 2 heating circuits with rotary mixing valves and electric actuators

DUO-ZONER 3L



DUO-ZONER 3P



Set 3P requires changing the supply side of the pump group to the left side



Set contains:

- Two-zone accumulation hydraulic separator **DUO-ZONER 45** (Cod.:606890) or **DUO-ZONER 70** (Cod.:606891),
- Two pump group **SMT 125 - DN 25**:
 - without pump (Cod.:606081),
 - with pump **Wilo Yonos Para 25/6** (Cod.:616084)
 - with pump **Grundfos UPM3S AUTO 25-60** (Cod.:616086)
 - with pump **DAB Evosta2** (Cod.:616087)
- Two check valves (Cod.:606031),
- Two actuators **MP 10 - 230 / 140** with adapter nr **A 101**(Cod.:401011).



DUO-ZONER 4 set - set of 2 heating circuits without mixing valves

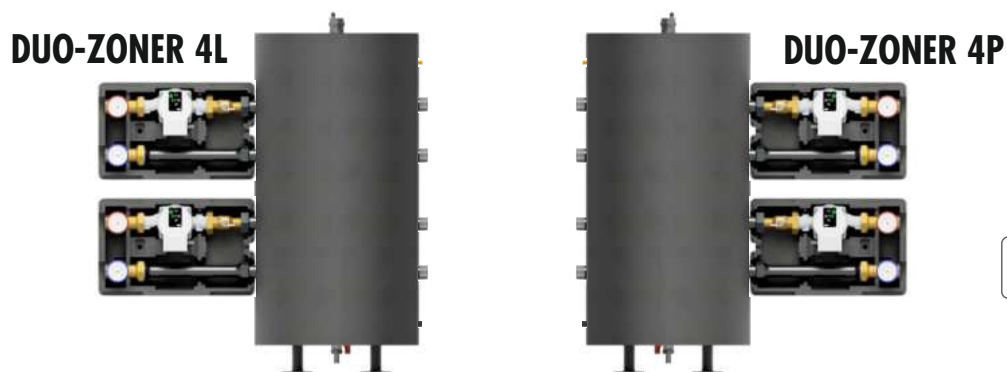

Set 4P requires changing the supply side of the pump group to the left side



Set contains:

1. Two-zone accumulation hydraulic separator **DUO-ZONER 45** (Cod.:606890) or **DUO-ZONER 70** (Cod.:606891),
2. Two pump group **SA 125 - DN 25**:
 - without pump (Cod.:606051),
 - with pump **Wilo Yonos Para 25/6** (Cod.:616054)
 - with pump **Grundfos UPM3S AUTO 25-60** (Cod.:616056)
 - with pump **DAB Evosta2** (Cod.:616057)

DUO-ZONER 5 set - set of 2 heating circuits with thermostatic mixing valves

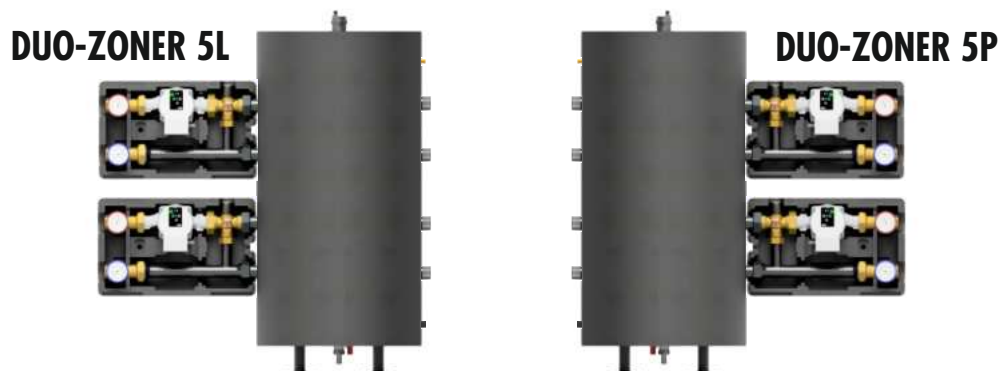

Set 5P requires changing the supply side of the pump group to the left side



Set contains:

1. Two-zone accumulation hydraulic separator **DUO-ZONER 45** (Cod.:606890) or **DUO-ZONER 70** (Cod.:606891),
2. Two pump group **SMTc1 125 - DN 25**:
 - without pump (Cod.:606071),
 - with pump **Wilo Yonos Para 25/6** (Cod.:616074)
 - with pump **Grundfos UPM3S AUTO 25-60** (Cod.:616076)
 - with pump **DAB Evosta2** (Cod.:616077)
3. Two check valves (Cod.:606031).



Multi-zone accumulation hydraulic separator MULTI-ZONER

Equipment:

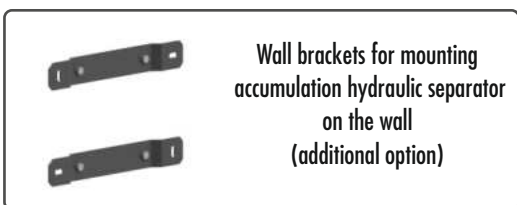
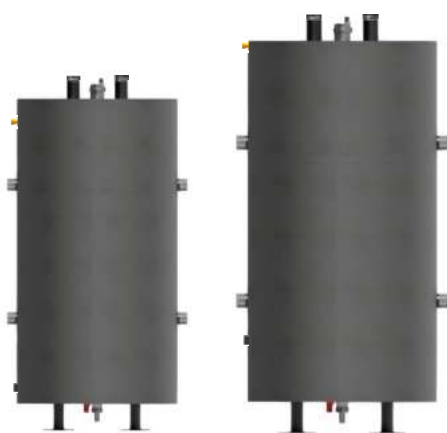
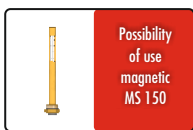
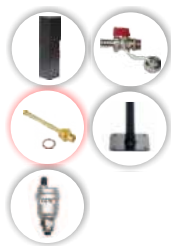

The multi-zone accumulation hydraulic separator MULTI-ZONER is made of steel. It works as a tank and a hydraulic separator with an output to the central heating system. Its task is to facilitate the operation of the heat pump in order to meet the heat demand with optimal modulation and to cover the peak loads with the support of an auxiliary heat source. Appropriate placement of connections and a partition ensures proper liquid stratification and maintaining an appropriate difference between the two temperature levels. The diameter and spacing of the connections allow direct connection of DN 25 pump groups in any configuration, making it possible to operate multiple heating circuits after using a C 60 or C 70 pump group zone manifold and connection of 2 heat sources. An additional sleeve allows the use of a magnetic insert MI 150 - DN 15. The product includes insulation, automatic air vent, immersion sleeve for the temperature sensor, drain valve and mounting feet.

Technical data:

Total capacity:	45 L or 70 L (depending on the model)
Insulation:	EPP black 60 g/l
Maximum pressure:	6 bar
Maximum temperature:	95 °C
Connection diameter:	
heat source side:	1" M
heating circuits side:	1" M
Spacing of connections:	
heat source side:	350 mm
heating circuits side:	125 mm

Type	Capacity [l]	Catalog number
Multi-zone accumulation hydraulic separator MULTI-ZONER 45	45	606795
Multi-zone accumulation hydraulic separator MULTI-ZONER 70	70	606796
Wall brackets for mounting on the wall		606799
Magnetic cartridge MS 150 - DN 15		607250

The system is designed to enable assembly pump groups on the wall

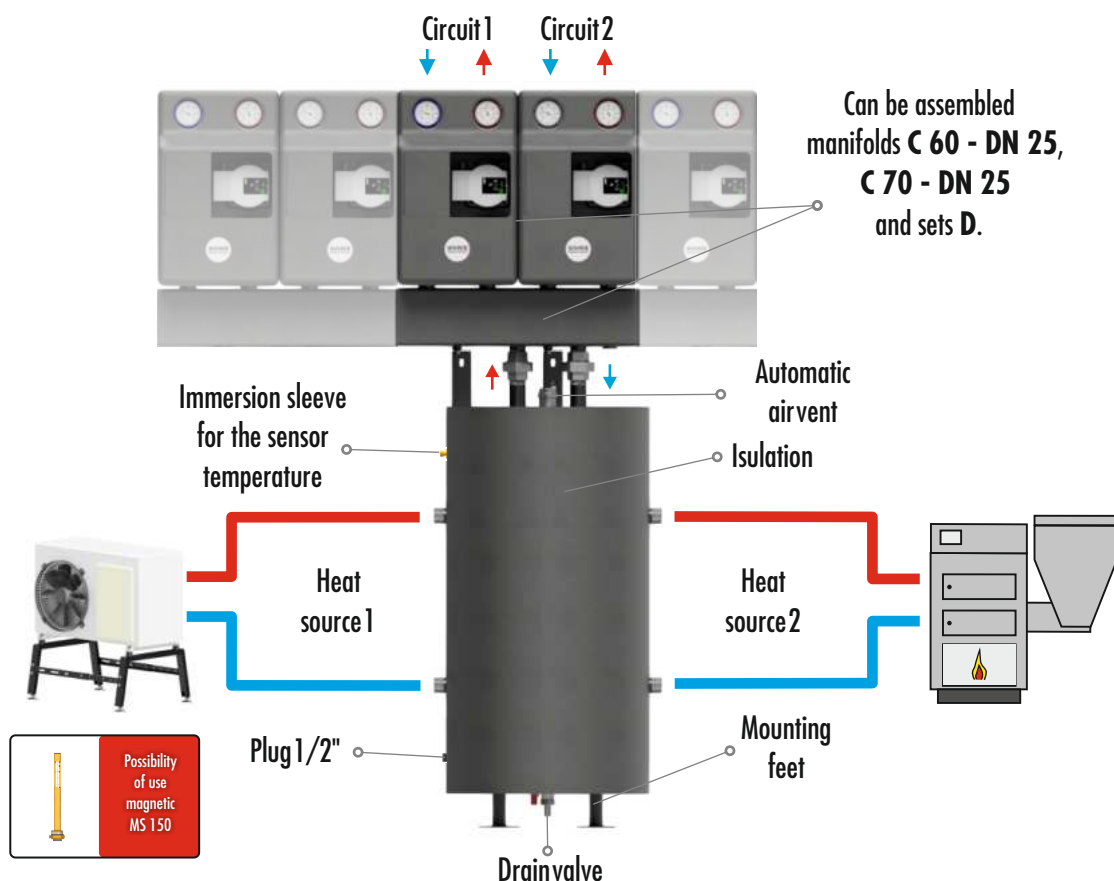
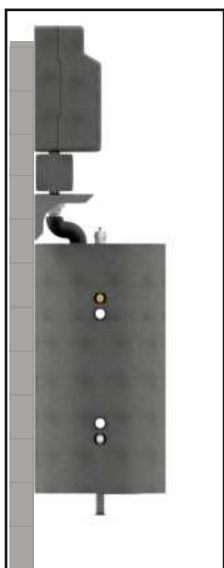

Can be assembled manifolds **C 60 - DN 25**, **C 70 - DN 25** and sets **D**.



Connection diagram of the DUO-ZONER

Simplified schematic diagram of the installation - the standard ones were not marked installation elements as well as the boiler room security scheme.

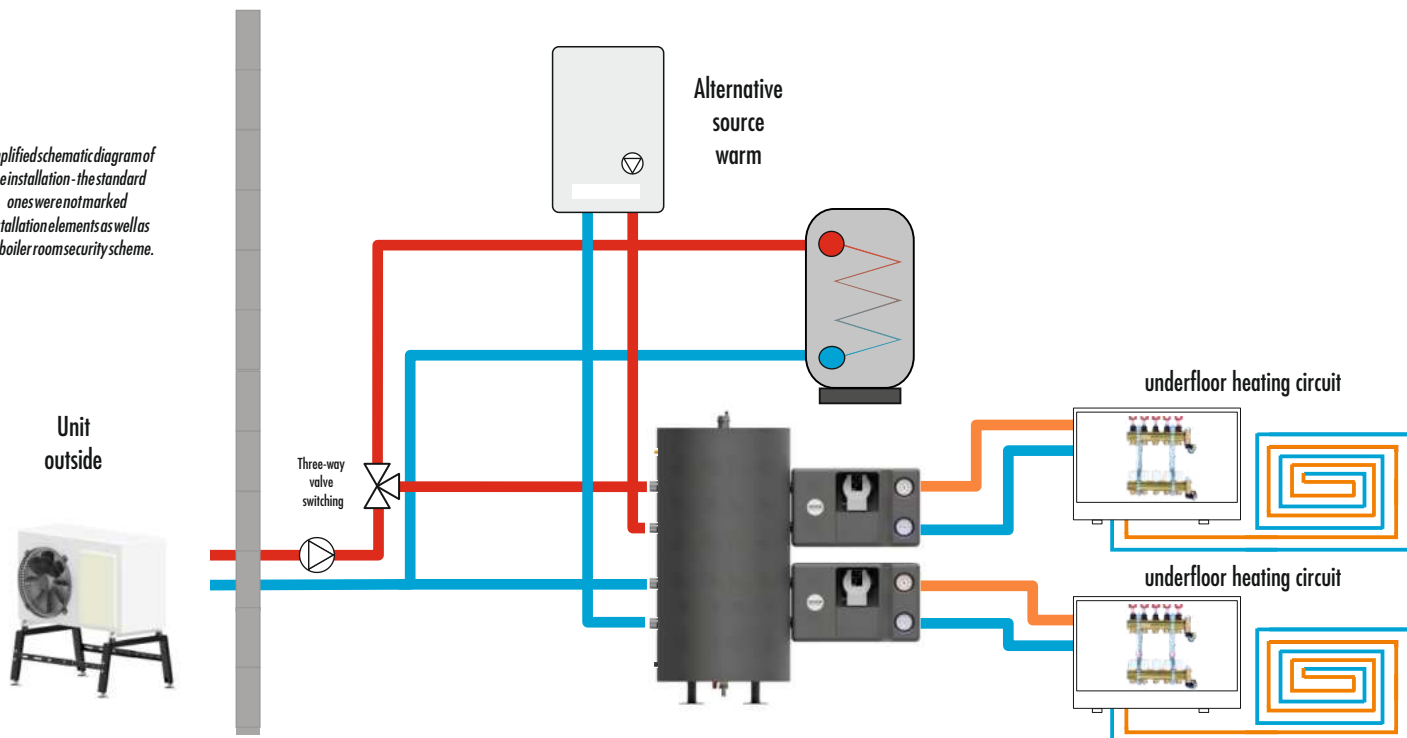

Connection diagram of the MULTI-ZONER

Simplified schematic diagram of the installation - the standard ones were not marked installation elements as well as the boiler room security scheme.

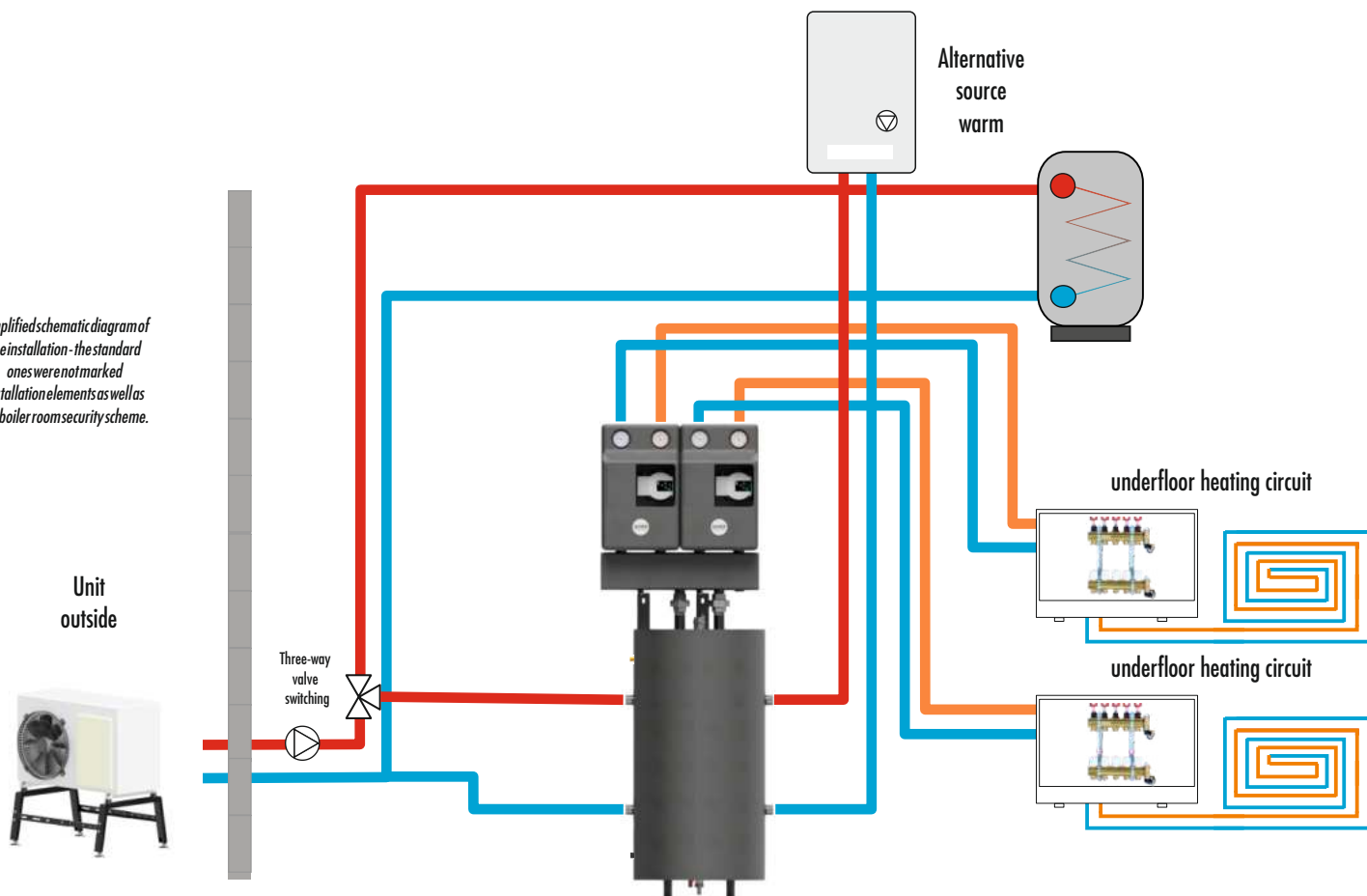

Buffer tanks

Equipment:



The hanging buffer tank has been designed to work with various heating devices, such as central heating boilers, or heat pumps to collect heat. It is equipped with brackets for mounting the device on the wall, an automatic air vent and an immersion sleeve for connecting a temperature sensor.

Technical data:

Total capacity:	45 L or 70 L (depending on the model)
Insulation:	EPP black
Maximum pressure:	6 bar
Maximum temperature:	95 °C
Connection diameter:	
heat source side:	1 1/4" M
heating circuit side:	1 1/4" M

Two tank capacities of 45 L and 70 L

Wall brackets included

Connections 1 1/4" M

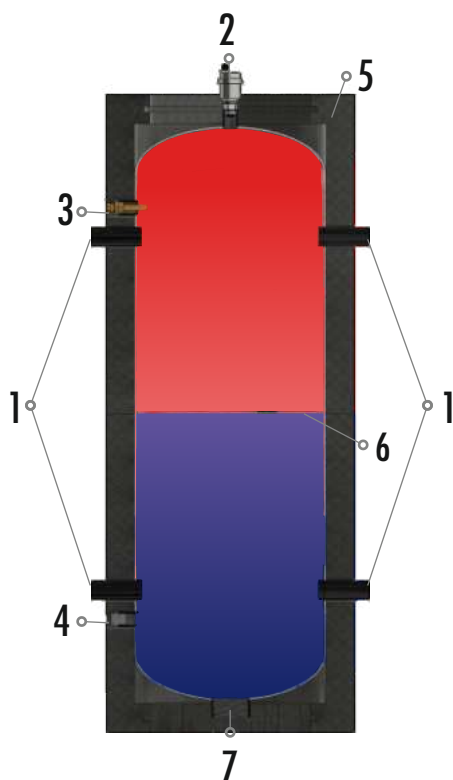

A simplified diagram of the internal structure

Tank description:

1. 1 1/4" M connections
2. Automatic air vent
3. 1/2" plunger sleeve for temperature sensor connection
4. Socket 1/2" for connection magnetic cartridge MI 150
5. EPP insulation
6. Incomplete septum
7. Socket 1 1/2" for connecting the heater

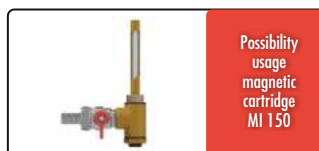

Possibility
usage
magnetic
cartridge
MI 150



Wall brackets
for mounting the
device on the
wall (included)

Type	Volume [l]	Catalog number
Hanging buffer tank 45L, with insulation, without coil	45	606781
Hanging buffer tank 70L, with insulation, without coil	70	606782
Magnetic cartridge MI 150 - DN 15		607255



Under-boiler magnetic filter PFM20

PFM20 - DN 20



PFM20 - DN 20 (with a connector and a ball valve)



The PFM 20 under-boiler magnetic filter is made of brass. It is equipped with a magnetic cartridge 12,000 G, a 500 μm mesh filter and a brass plug. The mesh filter inside eliminates solid impurities in the system, and a strong neodymium magnet collects and catches ferromagnetic impurities.

Thanks to its compact design, the PFM20 filter fits all types of boilers on the market with 3/4" M connections, and the brass body design guarantees long-term reliability of the product.

Technical data:

Material:	CW 617N brass
Maximum operating pressure:	6 bar
Maximum working temperature:	110 °C
Magnet:	12,000 G neodymium
Filter cartridge:	500 μm
The diameter of the connections:	3 x M 3/4" (for 100171)
	2 x external thread 3/4" , 1 x external thread 3/4" (for 100172)

Possible mounting positions

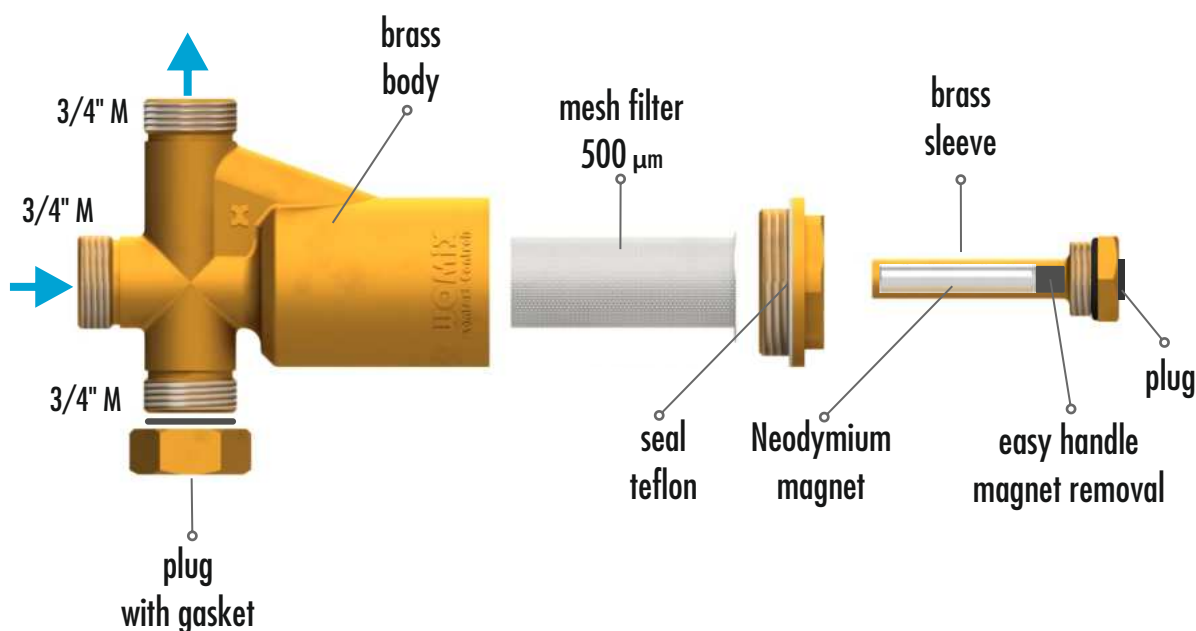
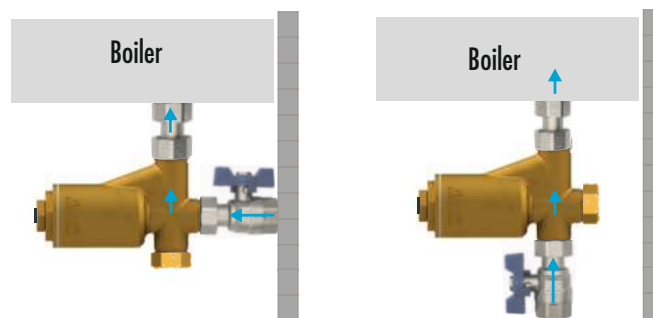

Type	Catalog number
Under-boiler magnetic filter PFM20 - DN 20	100171
Under-boiler magnetic filter PFM20 - DN 20 with connector and ball valve	100172



Pump group for hot utility water circulation HW20



The HW20 pump group is intended for the implementation of a hot utility water circulation system in installations with a domestic hot water tank. Its design allows you to avoid incorrect installation of the domestic hot water circulation system. The HW20 group is equipped with a thermostatic mixing valve MIX THERM (35 ÷ 60 ° C), with a kvs flow of 3.4, a ball valve with a thermometer, a circulation pump with a check valve and a return water thermometer. The group can be used for containers equipped with a circulation pipe as well as for containers not equipped with it.

Type	Catalog number
Pump group for hot utility water circulation HW20	606750

1. Circulation pump WOMIX eco Pro.
2. MIX THERM 35-60 ° C thermostatic mixing valve
3. Ball valve with thermometer
4. Drain / vent valve
5. Check valve
6. Bimetallic thermometer



Technical data:

Connection:	3x 3/4" F, 1x 1/2" F
Maximum static pressure:	10 bar
Maximum differential pressure:	5 bar
Min pressure:	0.2 bar
Flow rate:	70 l / min
Recommended working pressure:	1 - 5 bar
recommendation: for higher pressures it is recommended to install a pressure reducer	
Max. hot water temperature:	90 ° C
Adjustable temperature range:	35 - 60 ° C (+/- 2K)
Kvs:	3.4
Pump power:	8W
Pump supply voltage:	single-phase 200-240V 50/60 Hz



Hydraulic separator XP 80 - DN 32 ELEC

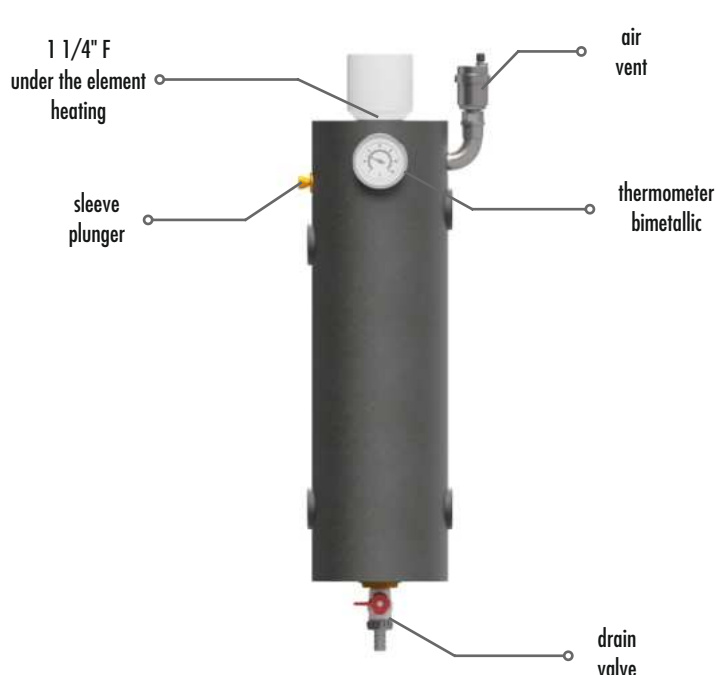

Hydraulic separator **XP 80 - DN 32 ELEC** for heating systems is made of steel. The factory is equipped with an automatic air vent, an immersion sleeve for connecting a temperature sensor, drain valve and EPP insulation. The hydraulic clutch **XP 80 ELEC** will prove itself in systems powered by a heat pump or a fireplace as an additional source of heat. Additionally, anti-freezing agent can be used in the installation of summer houses or buildings used occasionally.

Attention! The product does not contain a heater.

Attention! To prevent damage to the heating element during operation, a constant flow of medium through the device must be ensured.

Type	Catalog number
Hydraulic separator XP 80 - DN 32 ELEC with insulation, with equipment	609305
Hydraulic separator XP 100 - DN 40 ELEC with insulation, with equipment	609306

Flow heating tube HP 100 - DN 40

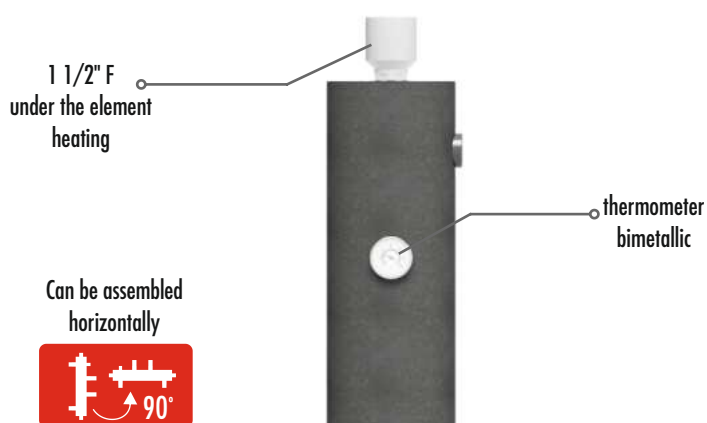

Flow heating tube **HP 100 - DN 40** for heating systems is made of steel. The factory is equipped with EPP insulation and a thermometer. The flow heating tube **HP 100 - DN 40** will work in systems powered by a heat pump or a fireplace as an additional source of heat. It can be used as a protection against freezing of the medium in the installations of summer houses or buildings used occasionally.

Technical data:

Material:	steel
Max pressure:	6 bar
Max temp.:	110°C
Insulation:	EPP black 60 g/l
Connections:	1 1/2" F
Electric heater thread required:	1 1/2" M

Attention! The product does not contain a heater. The maximum power of the heater is 6 kW.

Attention! To prevent damage to the heating element during operation, a constant flow of medium through the device must be ensured.

Type	Catalog number
Flow heating tube HP 100 - DN 40 with insulation,	609310



Steel profile manifold bar



Block (cage) manifolds are used in multi-family buildings, where on each floor it is necessary to separate the medium into several heating circuits. They are made of steel painted black and have 1/2" threaded connections for heating circuits and a threaded supply connection corresponding to the diameter of the manifold. On request, it is possible to make additional connections or manifolds in other diameters according to customer needs.

Technical data:

Material: steel

maximum working temperature: 95°C

working pressure: 6 bar

Installation side connection spacing: 100mm

Installation side connection diameter: GW 1/2"

Supply connection diameter:

for DN 20 - GW 3/4"

for DN 25 - 1" internal thread

for DN 32 - internal thread 1 1/4"

for DN 40 - internal thread 1 1/2"

Type	Catalog number
Steel profile manifold bar – DN 20/100mm – 2 circuits	621112
Steel profile manifold bar – DN 20/100mm – 3 circuits	621113
Steel profile manifold bar – DN 20/100mm – 4 circuits	621114
Steel profile manifold bar – DN 20/100mm – 5 circuits	621115
Steel profile manifold bar – DN 20/100mm – 6 circuits	621116
Type	Catalog number
Steel profile manifold bar – DN 25/100mm – 2 circuits	621122
Steel profile manifold bar – DN 25/100mm – 3 circuits	621123
Steel profile manifold bar – DN 25/100mm – 4 circuits	621124
Steel profile manifold bar – DN 25/100mm – 5 circuits	621125
Steel profile manifold bar – DN 25/100mm – 6 circuits	621126
Type	Catalog number
Steel profile manifold bar – DN 32/100mm – 2 circuits	621132
Steel profile manifold bar – DN 32/100mm – 3 circuits	621133
Steel profile manifold bar – DN 32/100mm – 4 circuits	621134
Steel profile manifold bar – DN 32/100mm – 5 circuits	621135
Steel profile manifold bar – DN 32/100mm – 6 circuits	621136
Type	Catalog number
Steel profile manifold bar – DN 40/100mm – 2 circuits	621142
Steel profile manifold bar – DN 40/100mm – 3 circuits	621143
Steel profile manifold bar – DN 40/100mm – 4 circuits	621144
Steel profile manifold bar – DN 40/100mm – 5 circuits	621145
Steel profile manifold bar – DN 40/100mm – 6 circuits	621146



Magnetic separators SM 20, SM 25



SM 20

Valves
ball
complete



SM 25

The SM magnetic separator is used to remove impurities in closed central heating systems. Contaminants in the circuit may accelerate the wear of pumps, valves and other components of the heating system. Contaminants can also restrict the flow of the system, thereby reducing the efficiency of the entire system. The separator can be installed in vertical or horizontal pipelines, and its unique design allows excellent filtration and deposition of impurities in the filter tank. Removal of impurities can take place during normal operation of the installation.

Technical data:

Maximum pressure: 4 bar

Maximum flow: 1.5 m³/h for SM 20

3.0 m³/h for SM 25

Type	Catalog number
Magnetic separator SM 20 - DN 20	500035
Magnetic separator SM 25 - DN 25	500036

Ball valve P 25

Ball valve
P 25



Group PG 25



Technical data:

Body: brass

Shaft seal: EPDM

Ball seal: Teflon

Maximum pressure: 6 bar

Maximum working temperature: 110°C

Installation connection: 1" F

Pump connection: 1 1/2" nut

Type	Catalog number
Ball valve P 25 with brass nut G 1 1/2" with gasket EPDM	700540
Group PG 25 - DN 25 (1"), with pump DAB Evosta2 65/180	700544



womix
Comfort Controls

CATALOG 2022

ENERGY-SAVING CENTRAL HEATING EQUIPMENT



mixing valves



hydraulic separators



boiler room building systems

www.womix.pl

Womix Sportowa 31 89-200 Szubin
phone: +48 52 382 44 50
mobile: 570 108 498



From design to productions

Qualified staff

A wide range of innovative products

Over 50 people employed in production

Express order fulfillment

High inventory

Automated production lines

Full production identification

Modern machinery park

Thousands of manufactured systems

Polish product

Quality certificate ISO 9001:2015



If there is a demand for non-standard products that are not included in our catalog our construction department is ready to prepare products that meet your technical and quality requirements.

PRODUCTS ADAPTED TO THE CUSTOMER'S NEEDS



MIXING VALVES

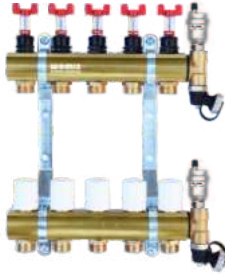

BRASS MANIFOLD WITH AUTOMATIC AIR VENTS



PRODUCTS WITH CUSTOMIZED CONNECTIONS

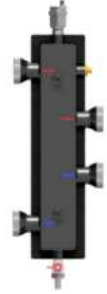

PRODUCTS ADAPTED TO THE CUSTOMER'S BRAND



PUMP GROUPS



MIX-BOX SYSTEM



ACTUATORS

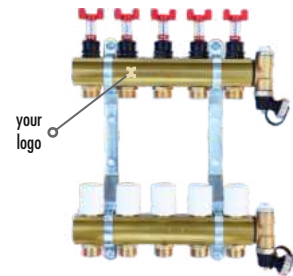

BRASS MANIFOLDS

CASCADE SYSTEMS ADAPTED TO THE REQUIREMENTS OF CUSTOMERS AND BOILER MANUFACTURERS

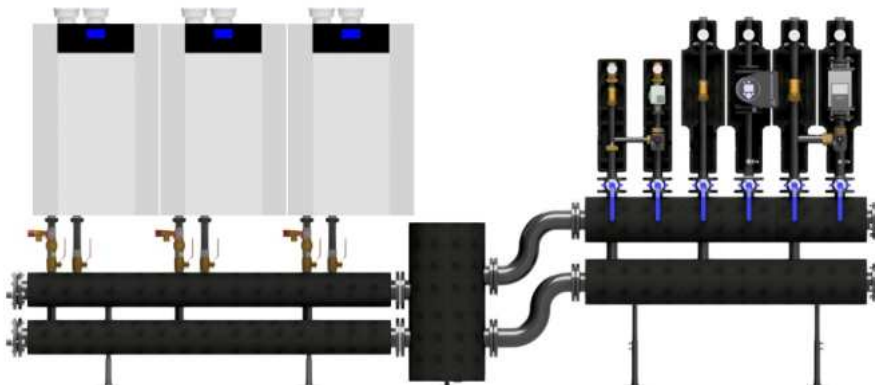

Table of Contents

Circulation pump Womix eco PRO 15-1/65	5
Pump groups M-SMTC - DN 20, M-SMT - DN 20	5
Brass zone manifolds CM	6-7
Actuators	8
Mixing and thermostatic valves	9-11
Hot water circulation, magnetic separators	12-13
Pressure reducing valves, filters	14-15
Ready-made pump group systems	16-28
Boiler room building system DN 20 - up to 35 kW	30-31
Pump groups DN 20	32
Boiler room building system DN 25 - from 40 kW to 110 kW	33-38
Pump groups DN 25	39
Boiler room building system DN 32 - from 120 kW to 220 kW	40-43
Pump groups DN 32	44
Boiler room building system DN 50 - up to 350 kW	45
Boiler room building system up to 700 kW	46-53
Heat pump or air conditioner stand/bracket, mounting frame for boiler	54
Elements for heating the central heating installation	55
Hydraulic separators	56-57
Other products	58

Circulation pump **WOMIX eco PRO**



Application:

Domestic hot water circulation installations.
Water circulation in heating systems.
Modernization and construction of new installations.
For single- and multi-family housing.

Type	Catalog number
Circulation pump WOMIX eco PRO 15-1/65	100151

Pump group **M-SMTC - DN 20** with thermostatic mixing valve

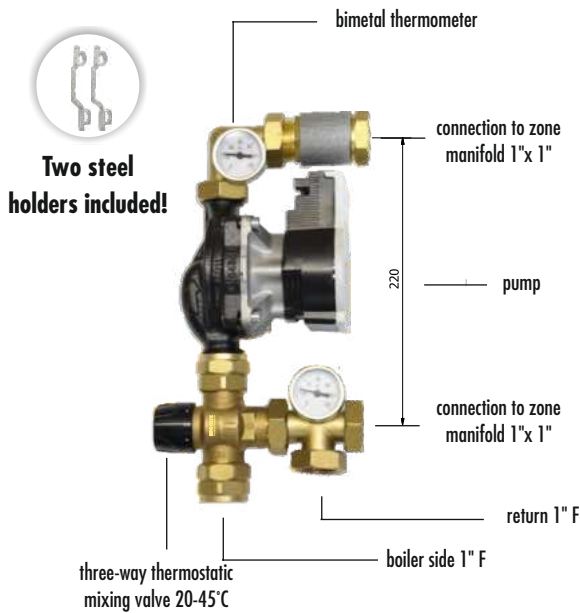

The mixing group **M-SMTC DN 20** with thermostatic valve is designed for floor heating manifolds. Its task is to limit the temperature of the medium introduced into the manifold. The group can be connected using a nipple (see table below) with all types of brass manifolds. The set consists of a 3-way thermostatic mixing valve (DN 20, temperature range 20-45 °C, kv 3,4), thermometer for supply and return water, brass connection fitting and Wilo, DAB or Grundfos pumps.

Type	Catalog number
Pump group M-SMTC - DN 20 without pump	200499
Pump group M-SMTC - DN 20 with pump Wilo Yonos Para 15/6	200491
Pump group M-SMTC - DN 20 with pump Grundfos UPM3S AUTO 15-60	200490
Pump group M-SMTC - DN 20 with pump DAB Evosta2 65/130	200492
Set two brass nipples G 1" with o-ring for connection pump with brass manifold	210020

Pump group **M-SMT - DN 20** with rotary mixing valve

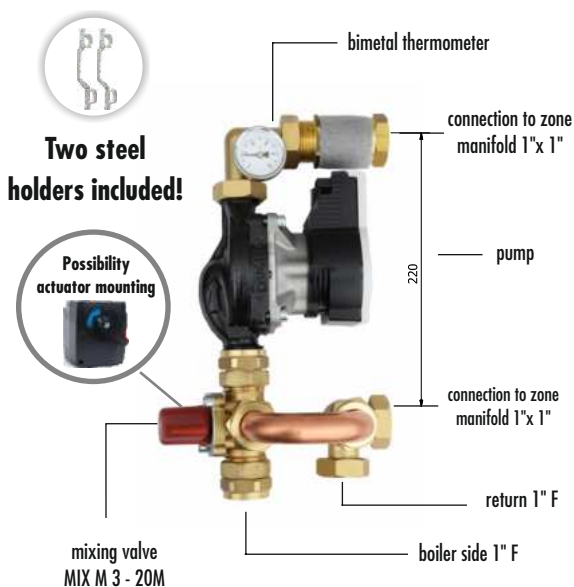

Mixing group **M-SMT - DN 20** with a rotary valve is designed for floor heating manifolds. Its task is to limit the temperature of the medium introduced into the manifold. The group can be connected using a nipple (see table below) with all types of brass manifolds. The set consists of a rotary mixing valve with a flow of kvs 6,3 with the possibility of connecting the actuator MP 10, thermometer for supply water, brass connection fitting and Wilo, DAB or Grundfos pumps.

Type	Catalog number
Pump group M-SMT - DN 20 without pump	200489
Pump group M-SMT - DN 20 with pump Wilo Yonos Para 15/6 130	200481
Pump group M-SMT - DN 20 with pump Grundfos UPM3S AUTO 15-60	200480
Pump group M-SMT - DN 20 with pump DAB Evosta2 65/130	200482
Set two brass nipples G 1" with o-ring for connection group with brass manifold	210020
Actuator MP 10	401011

Brass manifold for radiator heating **CM**

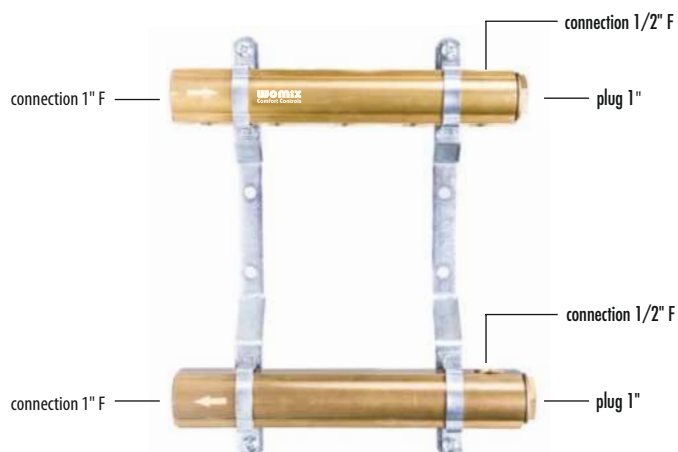

Brass manifold **CM** is responsible for distribution and regulation of the heating medium. The manifold allows connecting different circuits and installation zones, increasing the efficiency of the heating system. It contains two C-profile beams connected with two steel holders, connections for air vents and connections for supply and return of the system.

Name	Nr of sections	A (mm)	Catalog number
CM 2F	2	100	200102
CM 3F	3	150	200103
CM 4F	4	200	200104
CM 5F	5	250	200105
CM 6F	6	300	200106
CM 7F	7	350	200107
CM 8F	8	400	200108
CM 9F	9	450	200109
CM 10F	10	500	200110
CM 11F	11	550	200111
CM 12F	12	600	200112

Brass manifold for radiator heating **CM-N**

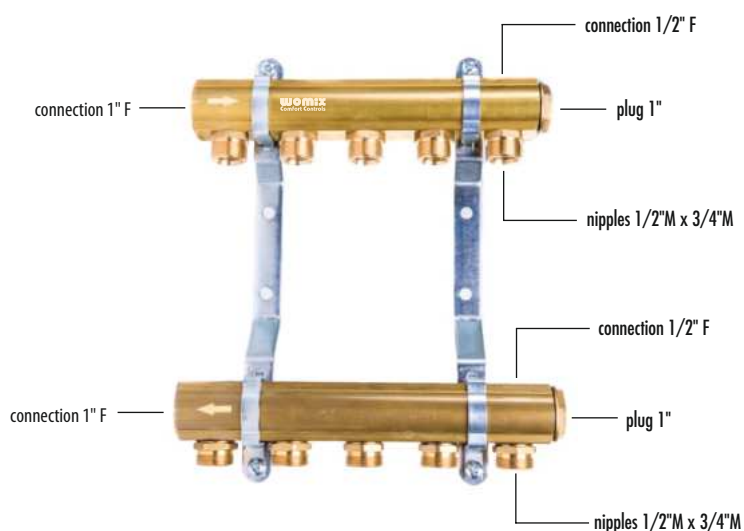

Brass manifold **CM-N** is responsible for distribution and regulation of the heating medium. The manifold allows connecting different circuits and installation zones, increasing the efficiency of the heating system. It contains two C-profile beams connected with two steel holders, connections for air vents, connections for supply and return of the system and nipples with an o-ring.

Name	Nr of sections	A (mm)	Catalog number
CM-N 2F	2	100	200202
CM-N 3F	3	150	200203
CM-N 4F	4	200	200204
CM-N 5F	5	250	200205
CM-N 6F	6	300	200206
CM-N 7F	7	350	200207
CM-N 8F	8	400	200208
CM-N 9F	9	450	200209
CM-N 10F	10	500	200210
CM-N 11F	11	550	200211
CM-N 12F	12	600	200212

Brass manifold for radiator and underfloor heating **CM-NR**

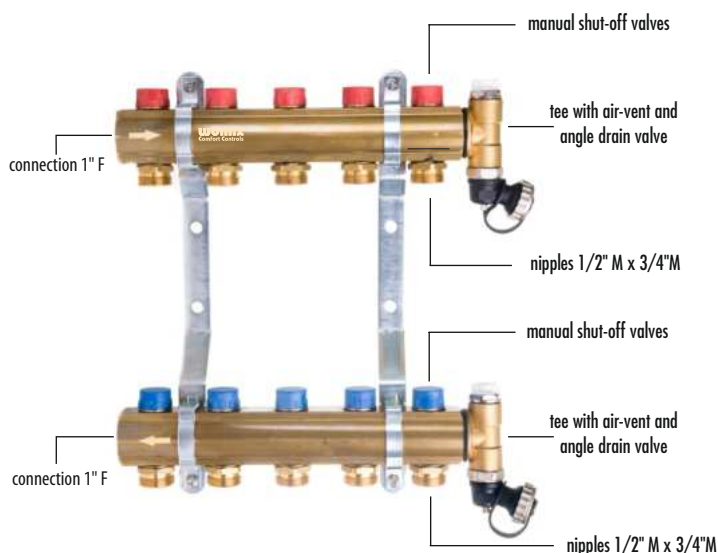

Brass manifold **CM-NR** is responsible for distribution and regulation of the heating medium. The manifold allows connecting different circuits and installation zones, increasing the efficiency of the heating system. It contains two C-profile beams connected with two steel holders, connections for supply and return of the system, nipples with an o-ring, manual shut-off valves and two brass tees with o-ring, manual air vent and angle drain valve.

Name	Nr of sections	A (mm)	Catalog number
CM-NR 2F	2	100	200302
CM-NR 3F	3	150	200303
CM-NR 4F	4	200	200304
CM-NR 5F	5	250	200305
CM-NR 6F	6	300	200306
CM-NR 7F	7	350	200307
CM-NR 8F	8	400	200308
CM-NR 9F	9	450	200309
CM-NR 10F	10	500	200310
CM-NR 11F	11	550	200311
CM-NR 12F	12	600	200312

Brass manifold for radiator heating and underfloor heating

Brass manifold for underfloor heating **CM-NRT**

Brass manifolds **CM-NRT** are used to separate individual loops of floor heating and their proper regulation, ensuring comfort of use and even distribution of heat. It contains two C-profile beams connected with two steel holders, connections for supply and return of the system, nipples with an o-ring, manual shut-off valves, regulating valves for actuators with M30x1,5 thread, two brass tees with o-ring, manual air vent and angle drain valve.

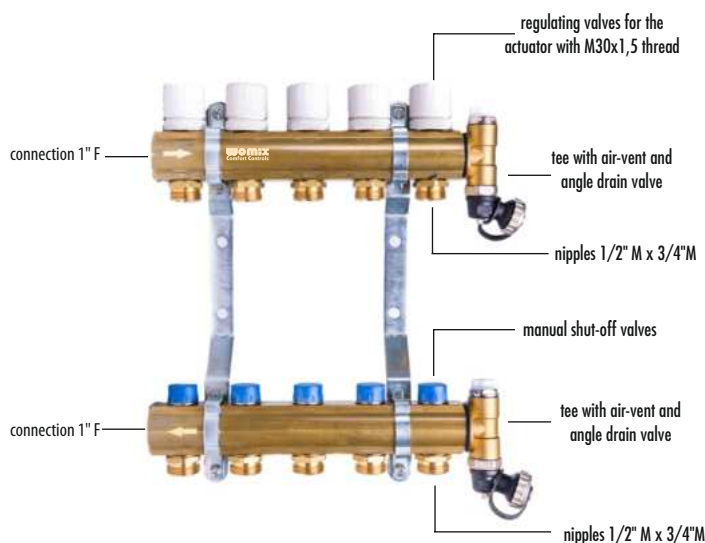

Name	Nr of sections	A (mm)	Catalog number
CM-NRT 2F	2	100	200402
CM-NRT 3F	3	150	200403
CM-NRT 4F	4	200	200404
CM-NRT 5F	5	250	200405
CM-NRT 6F	6	300	200406
CM-NRT 7F	7	350	200407
CM-NRT 8F	8	400	200408
CM-NRT 9F	9	450	200409
CM-NRT 10F	10	500	200410
CM-NRT 11F	11	550	200411
CM-NRT 12F	12	600	200412

Brass manifold for underfloor heating **CM-NTRot (0,5-5l/min)** and **CM-NTRot026 (0-2,6l/min)**

Brass manifolds **CM-NTRot** and **CM-NTRot026** are used to separate individual loops of floor heating and their proper regulation, ensuring comfort of use and even distribution of heat. Thanks to the rotameters placed on the supply beam, it is possible to precisely set the amount of medium flowing through each loop. The manifold contains two C-profile beams connected with two steel holders, connections for supply and return of the system, nipples with an o-ring, rotameters with a scale of 0,5 - 5 l/min or 0-2,6 l/min (depends on the type), regulating valves for actuators with M30x1,5 thread, two brass tees with o-ring, manual air vent and angle drain valve.

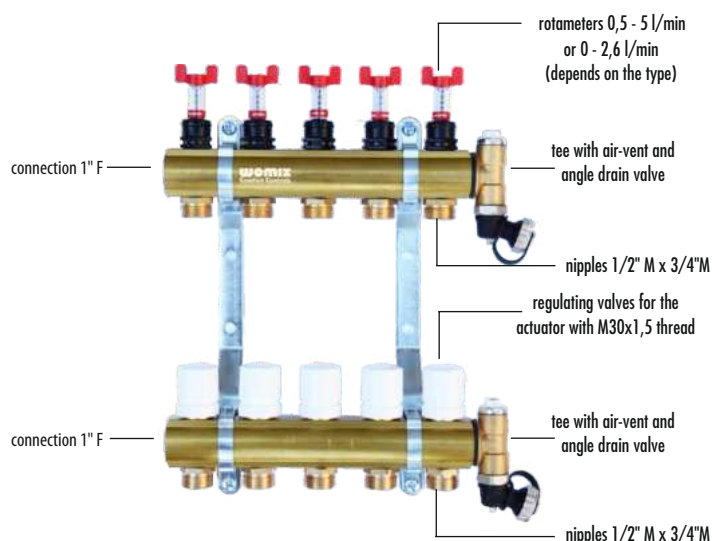

Nr of sections	A (mm)	Cod. CM-NTRot	Cod. CM-NTRot026
2	100	200502	200562
3	150	200503	200563
4	200	200504	200564
5	250	200505	200565
6	300	200506	200566
7	350	200507	200567
8	400	200508	200568
9	450	200509	200569
10	500	200510	200570
11	550	200511	200571
12	600	200512	200572

Equipment for brass manifolds

Type	Catalog number
Steel holder, L-220 mm	210001
Brass G 1" plug with O-ring seal	210002
Manual shut-off valve (red)	210004
Manual shut-off valve (blue)	210005
Regulating valves for the actuator with 30x1,5 thread	210006
Flow meter (rotameter) 0.5 - 5 l/min	210007
Flow meter (rotameter) 0 - 2,6 l/min	210017
Tee with air-vent and angle drain valve	210008
Manual air vent 1/2"	210009
Angle drain valve 1/2"	210010
Reducer nipple 1/2"x3/4" with seal O-ring with connection eurokonus - for manifold CM-N	210003
Reducer nipple 1/2"x3/4" with seal O-ring with connection eurokonus - for manual shut-of valve	210011
Reducer nipple 1/2"x3/4" with seal O-ring with connection eurokonus - for regulating valves	210012
Reducer nipple 1/2"x3/4" with seal O-ring with connection eurokonus - for flow meter	210013

Thermoelectric actuator **MP VM100**



The **MP VM100** thermoelectric actuator is a drive for opening and closing valves on manifolds of underfloor heating circuits. The set includes an adapter that allows the device to be mounted on thermostatic valves in the CM-NR, CM-NTRot and CM-NTRot026 manifolds. The adapter allows quick assembly of the actuator only by pressing and subsequent disassembly of the actuator only by using the disassembly button. The actuator is in the normally closed position, after energizing it opens the valve flow.

Type	Catalog number
Thermoelectric actuator MP VM100 with adapter for regulating valves Womix	401075

Actuator **MP 10, MP 15**



switch to work: manual / automatic.

MP actuators consists of a synchronous motor with capacitor, two limit switches, two cams positioned on the 90 degrees, the knob, the color scale for visualizing the position of the heart of the valve, a switch for manually changing the position of the heart of the valve. The factory is equipped with a 2 meter cable 3 x 0.75 mm² and an adapter for mounting the actuator on the mixing valve **MIX M** from WOMIX - **A 101**.

Using an adapter connecting actuators, **MP** can be mounted on the mixing valve manufacturing of other companies (see the numbers of adapters).

Actuator **MP 05 CR**

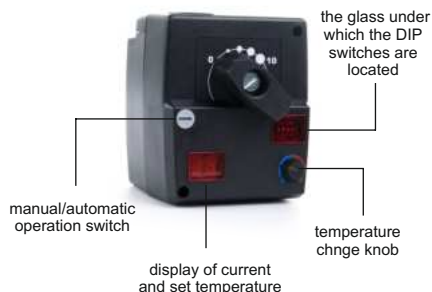

The actuators **MP 05 CR NEW** with integrated constant thermal regulator are used in central heating systems with mixing valve. The actuator maintains a constant temperature of the medium heating circuit. Through a built-in DIP switch (located under the cover of the actuator), we can choose additional functions such as:

- the direction of rotation of the actuator,
- the minimum temperature limit - a choice: +60...85°C,
- the maximum limit temperature - +25...45°C,
- change of response factor

Type	Torque	Open time	Voltage	Catalog number
Actuator MP 10 - 230 / 70 with adapter A 101 for valve by WOMIX	10 Nm	70 s./90°	230 V~50Hz	401010
Actuator MP 10 - 230 / 140 with adapter A 101 for valve by WOMIX	10 Nm	140 s./90°	230 V~50Hz	401011
Actuator MP 10 - 24 / 140 with adapter A 101 for valve by WOMIX	10 Nm	140 s./90°	24 V~50Hz	401012
Actuator MP 10 - 24 / 140 (0-10V) with adapter A 101 for valve by WOMIX	10 Nm	140 s./90°	24 V~50Hz	401041
Actuator MP 15 - 230 / 140 with adapter A 101 for valve by WOMIX	15 Nm	140 s./90°	230 V~50Hz	401031
Actuator MP 05 CR with built-in constant temperature control	5 Nm	140 s./90°	230 V, +/- 15V, 50/60 Hz	401050
Equipment				Catalog number
Adapter A 101 for MP 10 for valve by WOMIX (basic equipment)				401101
Adapter A 062 for valve by WITA Minimix and type H				401062
Adapter A 063 for valve by Meibes V7, Afrisio (old generation)				401063
Adapter A 064 for valve by ESBE, Danfoss (old generation)				401064
Adapter A 065 for valve by ESBE VRG / VRB				401065
Adapter A 066 for valve by WOMIX (old generation)				401066
Adapter A 151 for valve by WOMIX (for actuators MP 15)				401151

Mixing valves MIX M

MIX M 3



MIX M 4



Type	Kvs	Size	Catalog number
Mixing valve MIX M 3-15	4	1/2"	601000
Mixing valve MIX M 3-20	8	3/4"	601003
Mixing valve MIX M 3-25	12	1"	601005
Mixing valve MIX M 3-32	18	1 1/4"	601007
Mixing valve MIX M 3-40	28	1 1/2"	601008
Mixing valve MIX M 3-50	44	2"	601009

Type	Kvs	Size	Catalog number
Mixing valve MIX M 4-20	8	3/4"	602003
Mixing valve MIX M 4-25	12	1"	602005
Mixing valve MIX M 4-32	18	1 1/4"	602007
Mixing valve MIX M 4-40	28	1 1/2"	602008
Mixing valve MIX M 4-50	44	2"	602009

Mixing valve MIX M with actuator MP 10



Type	Catalog number
Mixing valve MIX M 3-20 kv 8 with actuator MP 10-230/140	601253
Mixing valve MIX M 3-25 kv 12 with actuator MP 10-230/140	601255
Mixing valve MIX M 3-32 kv 18 with actuator MP 10-230/140	601257
Mixing valve MIX M 4-20 kv 8 with actuator MP 10-230/140	602253
Mixing valve MIX M 4-25 kv 12 with actuator MP 10-230/140	602255
Mixing valve MIX M 4-32 kv 18 with actuator MP 10-230/140	602257

Mixing valve MIX M 3-20M - 1" M

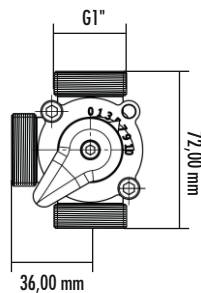

MIX M 3 - 20M is a valve with an external threads. It has three 1" threaded connections, and thanks to its compact dimensions, it can be used in many home boilers. The valve is also a part of the MIX-BOX systems.

Type	Kvs	Size	Catalog number
Mixing valve MIX M 3-20 M - 1" M	6,3	1"	601010

Mixing valve MIX MT 25, 32 for units SMT DN 25, 32



3-way mixing valve **MIX MT 25, 32** for straight-through flow, applies to small and medium-sized central heating system. It can be adjusted manually or automatically by the actuator **MP 10**.

Type	Kvs	Catalog number
Mixing valve MIX MT 25 - DN 25 with brass nut 1 1/2"	8,3	001021
Mixing valve MIX MT 32 - DN 32 with brass nut 2"	17	001022

Flanged mixing valves 3F, 4F

3 F



4 F



Type	Kvs	Size	Catalog number
Flanged mixing valve 3F - DN 32	28	32	601123
Flanged mixing valve 3F - DN 40	44	40	601124
Flanged mixing valve 3F - DN 50	60	50	601125
Flanged mixing valve 3F - DN 65	90	65	601126
Flanged mixing valve 3F - DN 80	150	80	601127
Flanged mixing valve 3F - DN 100	225	100	601128
Flanged mixing valve 3F - DN 125	280	125	601129
Flanged mixing valve 3F - DN 150	400	150	601030

Type	Kvs	Size	Catalog number
Flanged mixing valve 4F - DN 40	44	40	602124
Flanged mixing valve 4F - DN 50	60	50	602125
Flanged mixing valve 4F - DN 65	90	65	602126
Flanged mixing valve 4F - DN 80	150	80	602127
Flanged mixing valve 4F - DN 100	225	100	602128

Additional equipment for mixing valves **MIX M**

Connector for a flat seal to connect the mixing valve DN 25 with pump



Pump ball valve MF TERM 1 " with brass nut G 1 1/2", gasket

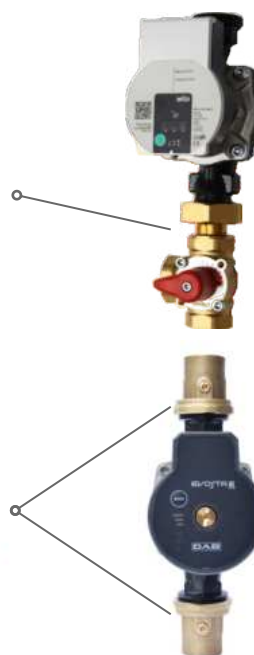

Type	Catalog number
Connector for a flat seal to connect the mixing valve DN 25 with pump, with brass nut	607222
Pump ball valve MF TERM 1 " with brass nut G 1 1/2", EPDM gasket	700540



Set o-rings for mixing valve

Type	Catalog number
Set o-rings for mixing valve MIX M DN 15, DN 20M	601090
Set o-rings for mixing valve MIX M DN 20, DN 25, DN 32	601091
Set o-rings for mixing valve MIX M DN 40, DN 50	601092

Thermostatic mixing valve **MIX THERM**



Thermostatic mixing valves **MIX THERM** series are designed to regulate the power factor of the installation of central heating radiators and floor heating.

Type	Catalog number
Thermostatic mixing valve MIX THERM 20-45 °C	601212
Thermostatic mixing valve MIX THERM 35-60 °C	601213

Thermostatic mixing valve **MIX THERM - R**



Thermostatic mixing valves **MIX THERM-R** series are designed to regulate the power factor of the installation of central heating radiators and floor. **MIX THERM-R** valve is equipped with a brass female nut 1 1/2" and 1" EPDM gasket.

Type	Catalog number
Thermostatic mixing valve MIX THERM-R 20-45 °C , with brass nut 1 1/2" F	601217
Thermostatic mixing valve MIX THERM-R 35-60 °C , with brass nut 1 1/2" F	601218

Thermostatic mixing valve **TMT**

TMT F



TMT M



Thermostatic mixing valves **TMT** series are designed to regulate domestic hot water. Protect the system against too high temperature hot water which in turn protects the user from burns. Do not install these valves in solar installations.

Type	Kvs	Catalog number
Thermostatic mixing valve TMT 12 F - 1/2"F	1,6	601101
Thermostatic mixing valve TMT 34 F - 3/4"F	1,8	601102
Thermostatic mixing valve TMT 34 M - 3/4"M	1,8	601103
Thermostatic mixing valve TMT 100 F - 1"F	3,2	601104
Thermostatic mixing valve TMT 100 M - 1"M	3,2	601105
Thermostatic mixing valve TMT 114 M - 1 1/4"M	7,4	601106
Thermostatic mixing valve TMT 112 M - 1 1/2"M	7,6	601107

Pump group for hot utility water circulation HW20

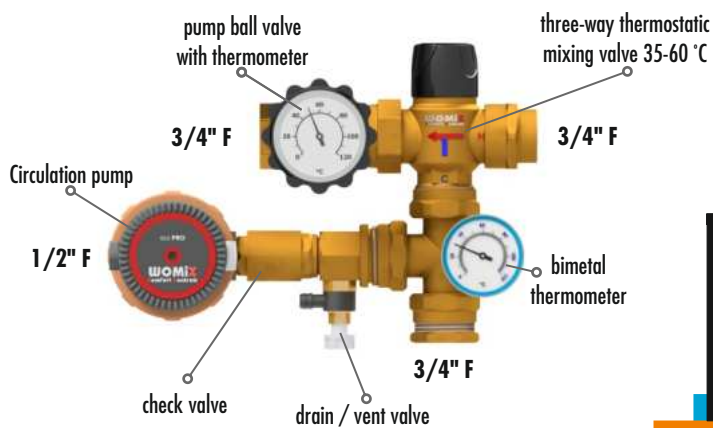

The HW20 pump group is intended for the implementation of a hot utility water circulation system in installations with a domestic hot water tank. Its design allows to avoid incorrect installation of the domestic hot water circulation system. The HW20 group is equipped with a thermostatic mixing valve MIX THERM (35 - 60 °C), with a kvs flow of 3,4, a ball valve with a thermometer, a circulation pump with a check valve, drain/vent valve and a return water thermometer. The group can be used for containers equipped with a circulation pipe as well as for containers not equipped with it.

Simplified schematic diagram of the installation - the standard installation elements as well as the boiler room protection scheme have not been marked.

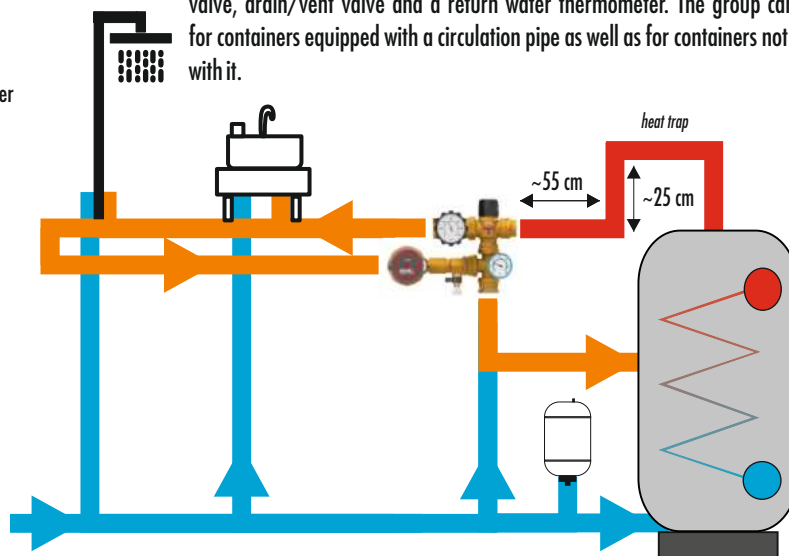

Type	Catalog number
Pump group for hot utility water circulation HW20	606750

Magnetic separators SM 20, SM 25



SM 20

Ball valves included



SM 25

The separator is used to remove water contaminants in closed central heating systems, especially sand and rust particles. Contaminants in the circuit can accelerate the wear of the water pump, valves and other components of the heating system. Dirt can also block the heat exchanger, the ends of the radiators or pipes, reducing the efficiency of the entire system. Due to its special design, the separator can be installed vertically or horizontally on vertical or horizontal pipelines. It enables excellent filtration and the deposition of impurities in the filter tank. Removal of contamination can occur during normal operation of the installation.

Type	Catalog number
Magnetic separators SM 20 - DN 20	500035
Magnetic separators SM 25 - DN 25	500036

Under-boiler magnetic filter PFM20

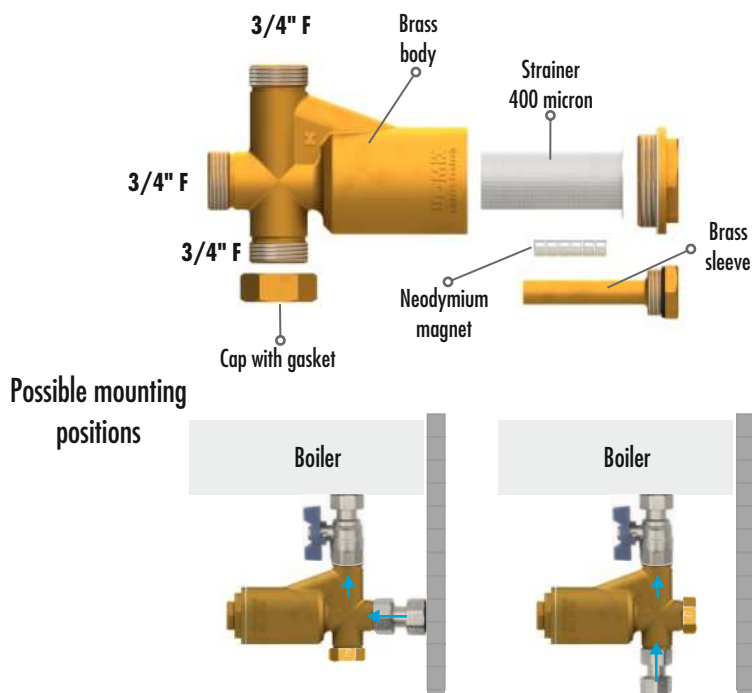

The PFM 20 under-boiler magnetic filter is made of brass. It is equipped with a 12000 G magnetic cartridge and brass plug. The magnetic filter eliminates impurities contained in the system thanks to the mesh filter inside. A strong neodymium magnet collects and catches all iron impurities, and solves all problems related to the protection of the boiler and heating installation thanks to its compact design.

Contamination in the installation can lead to:

- blockages and jamming of pumps caused by impurities that circulate in the pumps and can accumulate in them,
- lower efficiency of the heat exchangers due to the deposition of dirt, which can significantly reduce both the flow rate of the media and the heat exchange surface.

Thanks to the compact design of the dirt filter, it fits all types of boilers on the market.

Technical data:

Material:	brass CW 6N7N
Maximum working pressure	6 bar
Maximum working Temperature:	110°C
Magnet:	neodymium 12000 G

Type

Catalog number

Under-boiler magnetic filter PFM20 - DN 20

100171

Magnetic filter connection kit PFM20 (ball valve + connector)

100180

Automatic air vent Compact



Automatic air vents are installed to remove air that accumulates in heating and air conditioning systems. Thanks to their operation, without the need for manual operation, they allow to avoid harmful phenomena that may threaten the life and efficiency of hydraulic systems. In particular, they reduce the negative effect of galvanic corrosion (caused by the presence of oxygen inside the pipeline) and cavitation. Moreover, these valves optimize the heating and cooling capacity of any system as they prevent the formation of air pockets inside the radiators and fan coils.

Type

Catalog number

Automatic vertical air vent Compact, with a 1/2" check valve

100100

Compression fitting for multilayer and synthetic pipes with Euroconus connection



Type

Catalog number

Compression fitting for multilayer and synthetic pipes with Euroconus connection 3/4" x 16 x 2,0

210014



Pressure reducing valves **PRF** and **PRM**

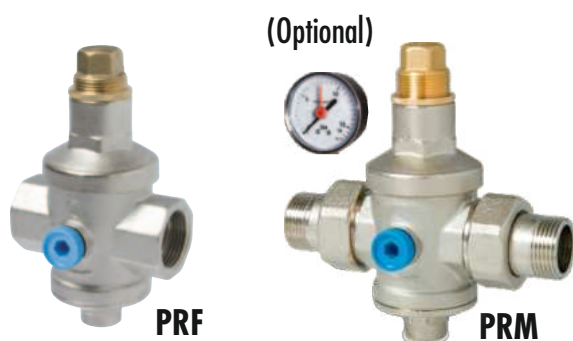

PRF

PRM

Pressure reducing valves are specially designed to reduce and stabilize the pressure of water flowing into the water supply network. Normally the pressure - from tap water - is too high and unstable to be used effectively in a domestic plumbing system. One of the most important features of pressure reducers is that they are able to provide a stable pressure downstream of the valve despite changing pressure upstream of the valve.

Type	Catalog number
Pressure reducing valve PRF 12F - F 1/2"	601600
Pressure reducing valve PRF 34F - F 3/4"	601601
Pressure reducing valve PRF 100F - F 1"	601602
Pressure reducing valve PRF 114F - F 1 1/4"	601603
Pressure reducing valve PRF 112F - F 1 1/2"	601604
Pressure reducing valve PRF 200F - F 2"	601605
Pressure reducing valve PRF 212F - F 2 1/2"	601606
Pressure reducing valve PRF 300F - F 3"	601607

Type	Catalog number
Pressure reducing valve PRM 12M - M 1/2"	601610
Pressure reducing valve PRM 34M - M 3/4"	601611
Pressure reducing valve PRM 100M - M 1"	601612
Pressure reducing valve PRM 114M - M 1 1/4"	601613
Pressure reducing valve PRM 112M - M 1 1/2"	601614
Pressure reducing valve PRM 200M - M 2"	601615
0-10 bar pressure gauge with radial connection for PRF and PRM pressure reducers	601619

Self-cleaning filter **FSV**

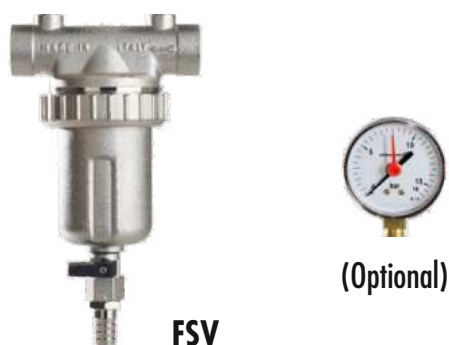

FSV

(Optional)

The self-cleaning filter is suitable for all plants, both civil and industrial ones, where the constant impurities in water could damage or block the present appliances. The water, we usually use, comes from waterworks or wells, contains a great number of particles which, according to their sizes, interact negatively with the installed accessories and compromise, therefore, their correct functioning. The joints for the connection to the hydraulic plant are internal threaded in compliance with the ISO 228/1 standard. On the body of the self-cleaning filter there are two 1/4"G threads for the connection of two pressure gauges. The self-cleaning filter is equipped with 400 micron filtering cartridge.

Type	Catalog number
Self-cleaning filter FSV 12F - F 1/2"	601650
Self-cleaning filter FSV 34F - F 3/4"	601651
Self-cleaning filter FSV 100F - F 1"	601652
Self-cleaning filter FSV 114F - F 1 1/4"	601653
Self-cleaning filter FSV 112F - F 1 1/2"	601654
Self-cleaning filter FSV 200F - F 2"	601655
0-16 bar pressure gauge with axial connection for FSV self-cleaning filters	601659

EASYFLUX ball valves with built-in filter



Easyflux ball valves are equipped with a sediment filter for water, which is located directly in the valve ball. Thanks to this solution, the length of the valve's installation is much shorter and the revolutionary way of installing the filter enables its maintenance and cleaning without removing the valve from the installation. The use of the filter in installations results in a significant improvement in water quality and protects the installation against solid contamination, thus extending its operation time. The version with a built-in magnetic cartridge also allows for the retention of metal particles in the installation and their removal when cleaning the filter.

Type	Catalog number
Ball valve with built-in filter Easyflux 1/2"	100101
Ball valve with built-in filter Easyflux 3/4"	100102
Ball valve with built-in filter Easyflux 1"	100103
Ball valve with built-in filter Easyflux 1 1/4"	100104
Ball valve with built-in filter Easyflux 1 1/2"	100105
Ball valve with built-in filter Easyflux 2"	100106

Type	Catalog number
Ball valve with built-in 3/4 " Easyflux filter, with magnetic insert	100162
Ball valve with built-in 1 " Easyflux filter, with magnetic insert	100163
Ball valve with built-in 1 1/4 " Easyflux filter, with magnetic insert	100164
Ball valve with built-in 1 1/2 " Easyflux filter, with magnetic insert	100165
Ball valve with built-in 2 " Easyflux filter, with magnetic insert	100166

Pump ball valves

Valve S TERM - Thermometer ball valve. (Mounted on the supply)

Valve S/C TERM - Thermometer ball valve with check valve. (Mounted on the return)

Valve S - Ball valve

Valve S/C TERM

Valve S TERM



Type	Catalog number
Pump ball valve S 1" with cast iron nut G 1 1/2" seal EPDM	700511
Pump ball valve S TERM 1" with cast iron nut G 1 1/2" seal EPDM	700521
Pump ball valve S/C TERM 1" with cast iron nut G 1 1/2" seal EPDM	700522
Type	Catalog number
Pump group G TERM - DN 25 (1"), without pump	700000
Pump group G TERM - DN 25 (1"), with pump Wilo Yonos Para 25/6	700008
Pump group G TERM - DN 25 (1"), with pump Wilo Yonos Para 25/8	700009
Pump group G TERM - DN 25 (1"), with pump Grundfos UPM3S AUTO 25-60	700003
Pump group G TERM - DN 25 (1"), with pump DAB Evosta2 65/180	700004
Type	Catalog number
Pump ball valve S 1 1/4" with cast iron nut G 2" seal EPDM	700611
Pump ball valve S TERM 1 1/4" with cast iron nut G 2" seal EPDM	700621
Pump ball valve S/C TERM 1 1/4" with cast iron nut G 2" seal EPDM	700622
Type	Catalog number
Pump group G TERM - DN 32 (1 1/4"), without pump	700010
Pump group G TERM - DN 32 (1 1/4"), with pump Wilo Yonos Para 30/6	700011
Pump group G TERM - DN 32 (1 1/4"), with pump Wilo Yonos Para 30/8	700012

SYSTEM MIX-BOX

for 2 or 3 heating circuits

Perfect products for wall-hanging boilers



Available with pumps:



Wilo Yonos Para DAB Evosta2 Grundfos UPM3

The **MIX-BOX SYSTEM** is a complete distribution system of heating circuits in the installation with wall-hanging boiler, both standard and condensing. It can handle up to three heating circuits. The heating circuits may be pumping or mixing with rotary or thermostatic mixing valve. Pump group are equipped with pump **Wilo - type Yonos Para 15/6**, **DAB - type Evosta2 65** or **Grundfos - type UPM3S AUTO 15 - 60**. The housing for **MIX-BOX** system is made in the wall version.

Technical data:

Zone manifold material:	steel, insulation black40 g/l
Pump groups material:	brass CW617N, copper
Max temp.:	95°C
Max. work pressure:	6 bar
Supply voltage pumps:	230 VAC, 50 Hz
Thermostatic mixing valve working temperature range:	20 - 45°C.
Lenght of pump:	130 mm
Connection of the pump:	1" M



Mixing valve
Kvs 6,3



Thermostatic
mixing valve
Kvs 3,4

Ready versions of MIX-BOX systems for two heating circuits

MIX-BOX 1 System of 2 heating circuits including one with a mixing valve and a rotary electric actuator



Type	Catalog number
System MIX-BOX 1 with groups SA/SMT 83, with pumps Wilo Yonos Para 15/6	604102
System MIX-BOX 1 with groups SA/SMT 83, with pumps Grundfos UPM3S AUTO 15 - 60	604121
System MIX-BOX 1 with groups SA/SMT 83, with pumps DAB Evosta2 65/130	604142

The system contains:

1. Wall cabinet P2 (catalog no: 604003),
2. Zone manifold CX 2F (catalog no: 604012),
3. Group SA 83 MIX-BOX 20 with pump,
4. Group SMT 83 MIX-BOX 20 with pump,



MIX-BOX 2 System of 2 heating circuits including one with thermostatic mixing valve



Type	Catalog number
System MIX-BOX 2 with groups SA/SMTC 83, with pumps Wilo Yonos Para 15/6	604104
System MIX-BOX 2 with groups SA/SMTC 83, with pumps Grundfos UPM3S AUTO 15 - 60	604123
System MIX-BOX 2 with groups SA/SMTC 83, with pumps DAB Evosta2 65/130	604144

The system contains:

1. Wall cabinet P2 (catalog no: 604003),
2. Zone manifold CX 2F (catalog no: 604012),
3. Group SA 83 MIX-BOX 20 with pump,
4. Group SMTC 83 MIX-BOX 20 with pump,



MIX-BOX 3 System of 2 heating circuits with a mixing valves and a rotary electric actuators



Type	Catalog number
System MIX-BOX 3 with groups SMT/SMT 83, with pumps Wilo Yonos Para 15/6	604106
System MIX-BOX 3 with groups SMT/SMT 83, with pumps Grundfos UPM3S AUTO 15 - 60	604125
System MIX-BOX 3 with groups SMT/SMT 83, with pumps DAB Evosta2 65/130	604146

The system contains:

1. Wall cabinet P2 (catalog no: 604003),
2. Zone manifold CX 2F (catalog no: 604012),
3. Group SMT 83 MIX-BOX 20 with pump,
4. Group SMT 83 MIX-BOX 20 with pump,



Ready versions of MIX-BOX systems for two heating circuits

MIX-BOX 4 System of 2 direct heating circuits without a mixing valves



Type	Catalog number
System MIX-BOX 4 with groups SA/SA 83, with pumps Wilo Yonos Para 15/6	604108
System MIX-BOX 4 with groups SA/SA 83, with pumps Grundfos UPM3S AUTO 15 - 60	604127
System MIX-BOX 4 with groups SA/SA 83, with pumps DAB Evosta2 65/130	604148

The system contains:

1. Wall cabinet **P2** (catalog no: 604003),
2. Zone manifold **CX 2F** (catalog no: 604012),
3. Group **SA 83 MIX-BOX 20** with pump,
4. Group **SA 83 MIX-BOX 20** with pump,



MIX-BOX 5 System of 2 heating circuits with thermostatic mixing valves



Type	Catalog number
System MIX-BOX 5 with groups SMTC/SMTC 83, with pumps Wilo Yonos Para 15/6	604110
System MIX-BOX 5 with groups SMTC/SMTC 83, with pumps Grundfos UPM3S AUTO 15 - 60	604129
System MIX-BOX 5 with groups SMTC/SMTC 83, with pumps DAB Evosta2 65/130	604150

The system contains:

1. Wall cabinet **P2** (catalog no: 604003),
2. Zone manifold **CX 2F** (catalog no: 604012),
3. Group **SMTC 83 MIX-BOX 20** with pump,
4. Group **SMTC 83 MIX-BOX 20** with pump,



MIX-BOX 6 System of 2 heating circuits including one with a mixing valve and a actuator with built-in constant temperature control



Type	Catalog number
System MIX-BOX 6 with groups SA/SMT CR 83, with pumps Wilo Yonos Para 15/6	604112
System MIX-BOX 6 with groups SA/SMT CR 83, with pumps Grundfos UPM3S AUTO 15 - 60	604131
System MIX-BOX 6 with groups SA/SMT CR 83, with pumps DAB Evosta2 65/130	604152

The system contains:

1. Wall cabinet **P2** (catalog no: 604003),
2. Zone manifold **CX 2F** (catalog no: 604012),
3. Group **SA 83 MIX-BOX 20** with pump,
4. Group **SMT CR 83 MIX-BOX 20** with pump,



MIX-BOX 111 - System of 3 direct heating circuits without a mixing valves



Type	Catalog number
System MIX-BOX 111 with groups SA/SA/SA 83, with pumps Wilo Yonos Para 15/6	604201
System MIX-BOX 111 with groups SA/SA/SA 83, with pumps Grundfos UPM3S AUTO 15 - 60	604202
System MIX-BOX 111 with groups SA/SA/SA 83, with pumps DAB Evosta2 65/130	604203

Set contains:

1. P3 wall cabinet (catalog no. : 604002)
2. Manifold CX 3F (catalog no. : 604011)
3. Pump group SA 83 MIX BOX 20 with pump
4. Pump group SA 83 MIX BOX 20 with pump
5. Pump group SA 83 MIX BOX 20 with pump

3x



Zestaw MIX-BOX 112 - System of 3 heating circuits - two without mixing valves and one with a mixing valve rotary and electric actuator



Type	Catalog number
System MIX-BOX 112 with groups SA/SA/SMT 83, with pumps Wilo Yonos Para 15/6	604205
System MIX-BOX 112 with groups SA/SA/SMT 83, with pumps Grundfos UPM3S AUTO 15 - 60	604206
System MIX-BOX 112 with groups SA/SA/SMT 83, with pumps DAB Evosta2 65/130	604207

Set contains:

1. P3 wall cabinet (catalog no. : 604002)
2. Manifold CX 3F (catalog no. : 604011)
3. Pump group SA 83 MIX BOX 20 with pump
4. Pump group SA 83 MIX BOX 20 with pump
5. Pump group SMT 83 MIX BOX 20 with pump



1x



MIX-BOX 113 - set of 3 heating circuits - two without mixing valves and one with thermostatic mixing valve



Type	Catalog number
System MIX-BOX 113 with groups SA/SA/SMTC 83, with pumps Wilo Yonos Para 15/6	604301
System MIX-BOX 113 with groups SA/SA/SMTC 83, with pumps Grundfos UPM3S AUTO 15 - 60	604302
System MIX-BOX 113 with groups SA/SA/SMTC 83, with pumps DAB Evosta2 65/130	604303

Set contains:

1. P3 wall cabinet (catalog no. : 604002)
2. Manifold CX 3F (catalog no. : 604011)
3. Pump group SA 83 MIX BOX 20 with pump
4. Pump group SA 83 MIX BOX 20 with pump
5. Pump group SMTC 83 MIX BOX 20 with pump



1x



MIX-BOX 122 - a set of 3 heating circuits - one without a mixing valve and two with mixing valves rotary and electric actuators



Type	Catalog number
System MIX-BOX 122 with groups SA/SMT/SMT 83, with pumps Wilo Yonos Para 15/6	604305
System MIX-BOX 122 with groups SA/SMT/SMT 83, with pumps Grundfos UPM3S AUTO 15 - 60	604306
System MIX-BOX 122 with groups SA/SMT/SMT 83, with pumps DAB Evosta2 65/130	604307

Set contains:

1. P3 wall cabinet (catalog no. : 604002)
2. Manifold CX 3F (catalog no. : 604011)
3. Pump group SA 83 MIX BOX 20 with pump
4. Pump group SMT 83 MIX BOX 20 with pump
5. Pump group SMT 83 MIX BOX 20 with pump



2x



MIX-BOX 132 - a set of 3 heating circuits - one without a mixing valve, one with a thermostatic valve mixing valve and one with mixing rotary valve and electric actuator



Type	Catalog number
System MIX-BOX 132 with groups SA/SMT/SMTC 83, with pumps Wilo Yonos Para 15/6	604401
System MIX-BOX 132 with groups SA/SMT/SMTC 83, with pumps Grundfos UPM3S AUTO 15 - 60	604402
System MIX-BOX 132 with groups SA/SMT/SMTC 83, with pumps DAB Evosta2 65/130	604403

Set contains:

1. P3 wall cabinet (catalog no. : 604002)
2. Manifold CX 3F (catalog no. : 604011)
3. Pump group SA 83 MIX BOX 20 with pump
4. Pump group SMTC 83 MIX BOX 20 with pump
5. Pump group SMT 83 MIX BOX 20 with pump



MIX-BOX 133 - a set of 3 heating circuits - one without a mixing valve and two with thermostatic ones mixing valves



Type	Catalog number
System MIX-BOX 133 with groups SA/SMTC/SMTC 83, with pumps Wilo Yonos Para 15/6	604405
System MIX-BOX 133 with groups SA/SMTC/SMTC 83, with pumps Grundfos UPM3S AUTO 15 - 60	604406
System MIX-BOX 133 with groups SA/SMTC/SMTC 83, with pumps DAB Evosta2 65/130	604407

Set contains:

1. P3 wall cabinet (catalog no. : 604002)
2. Manifold CX 3F (catalog no. : 604011)
3. Pump group SA 83 MIX BOX 20 with pump
4. Pump group SMTC 83 MIX BOX 20 with pump
4. Pump group SMTC 83 MIX BOX 20 with pump



MIX-BOX 222 - set of 3 heating circuits - with rotary mixing valves and electric actuators



Type	Catalog number
System MIX-BOX 222 with groups SMT/SMT/SMT 83, with pumps Wilo Yonos Para 15/6	604501
System MIX-BOX 222 with groups SMT/SMT/SMT 83, with pumps Grundfos UPM3S AUTO 15 - 60	604502
System MIX-BOX 222 with groups SMT/SMT/SMT 83, with pumps DAB Evosta2 65/130	604503

Set contains:

1. P3 wall cabinet (catalog no. : 604002)
2. Manifold CX 3F (catalog no. : 604011)
3. Pump group SMT 83 MIX BOX 20 with pump
4. Pump group SMT 83 MIX BOX 20 with pump
5. Pump group SMT 83 MIX BOX 20 with pump



MIX-BOX 223 - set of 3 heating circuits - two with mixing rotary valves and electric actuators and one with a thermostatic mixing valve



Type	Catalog number
System MIX-BOX 223 with groups SMT/SMT/SMTC 83, with pumps Wilo Yonos Para 15/6	604505
System MIX-BOX 223 with groups SMT/SMT/SMTC 83, with pumps Grundfos UPM3S AUTO 15 - 60	604506
System MIX-BOX 223 with groups SMT/SMT/SMTC 83, with pumps DAB Evosta2 65/130	604507

Set contains:

1. P3 wall cabinet (catalog no. : 604002)
2. Manifold CX 3F (catalog no. : 604011)
3. Pump group SMT 83 MIX BOX 20 with pump
4. Pump group SMT 83 MIX BOX 20 with pump
5. Pump group SMTC 83 MIX BOX 20 with pump



MIX-BOX 233 - set of 3 heating circuits - one with a rotary mixing valve and electric actuator and two with thermostatic mixing valve



Type	Catalog number
System MIX-BOX 233 with groups SMT/SMTC/SMTC 83, with pumps Wilo Yonos Para 15/6	604601
System MIX-BOX 233 with groups SMT/SMTC/SMTC 83, with pumps Grundfos UPM3S AUTO 15 - 60	604602
System MIX-BOX 233 with groups SMT/SMTC/SMTC 83, with pumps DAB Evosta2 65/130	604603

Set contains:

1. P3 wall cabinet (catalog no. : 604002)
2. Manifold CX 3F (catalog no. : 604011)
3. Pump group SMT 83 MIX BOX 20 with pump
4. Pump group SMTC 83 MIX BOX 20 with pump
5. Pump group SMTC 83 MIX BOX 20 with pump



MIX-BOX 333 - set of 3 heating circuits - with thermostatic mixing valves



Type	Catalog number
System MIX-BOX 333 with groups SMTC/SMTC/SMTC 83, with pumps Wilo Yonos Para 15/6	604605
System MIX-BOX 333 with groups SMTC/SMTC/SMTC 83, with pumps Grundfos UPM3S AUTO 15 - 60	604606
System MIX-BOX 333 with groups SMTC/SMTC/SMTC 83, with pumps DAB Evosta2 65/130	604607

Set contains:

1. P3 wall cabinet (catalog no. : 604002)
2. Manifold CX 3F (catalog no. : 604011)
3. Pump group SMTC 83 MIX BOX 20 with pump
4. Pump group SMTC 83 MIX BOX 20 with pump
5. Pump group SMTC 83 MIX BOX 20 with pump



Cabinet mounting for the system MIX-BOX - wall-mounted version P



Galvanized plate material. Closing cabinet powder painted - white.
The dimensions of the cabinet P2 for 2 heating circuits: 590x350x190 (height / width / depth).

The dimensions of the cabinet P3 for 3 heating circuits: 590x510x190 (height / width / depth).

Type	Catalog number
Wall-mounted cabinet P2 for 2 heating circuits	604003
Wall-mounted cabinet P3 for 3 heating circuits	604002

Zone manifold for CX 2- or 3-circuits

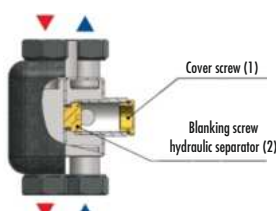

The MINI hydraulic separator
The flow diagram between supply and return.

Zone manifold CX is made of black painted steel and insulated. It is equipped with mini-hydraulic separator, which by end cap can be opened (see picture).

Type	Catalog number
Zone manifold CX 2F for 2 heating circuits	604012
Zone manifold CX 3F for 3 heating circuits	604011

Attention! Normally, the mini hydraulic separator in the CX zone manifold is closed.

Pump group SA 83 MIX-BOX 20



Pump group SA 83 MIX-BOX 20 without mixing valve is equipped with a check valve, a set of insulated connecting pipes. Pump groups are available without pumps or with Wilo, Grundfos or DAB.

Pump group SMT 83 MIX-BOX 20

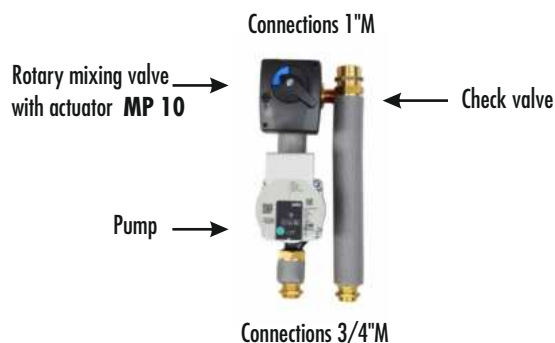

Pump group SMT 83 MIX-BOX 20 is equipped with a 3-way rotary mixing valve MIX M 3-20M (kv 6.3), check valve, a set of insulated connecting pipes, mixing valve actuator MP 10-230 / 140. Pump groups are available without pumps or with Wilo, Grundfos or DAB.

Type	Catalog number	Type	Catalog number
Pump group SA 83 MIX-BOX 20 without pump	604061	Pump group SMT 83 MIX-BOX 20 without pump	604081
Pump group SA 83 MIX-BOX 20 with Wilo Yonos Para 15/6	604062	Pump group SMT 83 MIX-BOX 20 with Wilo Yonos Para 15/6	604082
Pump group SA 83 MIX-BOX 20 with Grundfos UPM3S AUTO 15 - 60	604065	Pump group SMT 83 MIX-BOX 20 with Grundfos UPM3S AUTO 15 - 60	604085
Pump group SA 83 MIX-BOX 20 with DAB Evosta2 65/130	604068	Pump group SMT 83 MIX-BOX 20 with DAB Evosta2 65/130	604087

Pump group SMTc 83 MIX-BOX 20

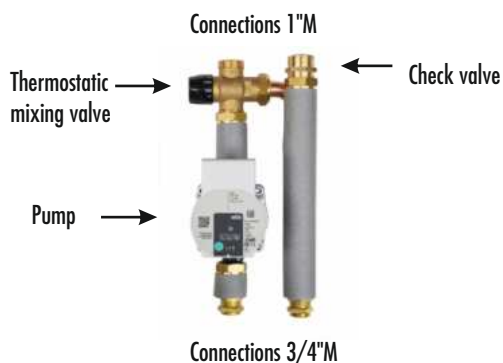

Pump group SMTc 83 MIX-BOX 20 is equipped with a 3-way thermostatic mixing valve (DN 20, the range 20-45 C, kv 3,4), check valve, a set of insulated connecting pipes. Pump groups are available without pumps or with Wilo, Grundfos or DAB.

Pump group SMT CR 83 MIX-BOX 20



The mixing and pump group SMT CR 83 MIX-BOX 20 is equipped with a 3-way mixing valve MIX M 3-20M - GZ 1" - Kvs 6.3, a check valve, pipe insulation. Moreover, the group is equipped with a Wilo, Grundfos or DAB pump and in the MP 05 CR mixing valve actuator with a built-in constant temperature regulator.

Type	Catalog number	Type	Catalog number
Pump group SMTc 83 MIX-BOX 20 without pump	604071	Pump group SMT CR 83 MIX-BOX 20 without pump	604080
Pump group SMTc 83 MIX-BOX 20 with Wilo Yonos Para 15/6	604072	Pump group SMT CR 83 MIX-BOX 20 with Wilo Yonos Para 15/6	604086
Pump group SMTc 83 MIX-BOX 20 with Grundfos UPM3S AUTO 15-60	604075	Pump group SMT CR 83 MIX-BOX 20 with Grundfos UPM3S AUTO 15-60	604088
Pump group SMTc 83 MIX-BOX 20 with DAB Evosta2 65/130	604078	Pump group SMT CR 83 MIX-BOX 20 with DAB Evosta2 65/130	604098

Hydraulic separator CPN MIX-BOX



The hydraulic separator CPN MIX-BOX is made of steel. The factory is equipped with insulation, immersion sleeve for temperature sensor and the automatic air vent with check valve.

Hydraulic separator CPN MIX-BOX has been produced to ensure the full adjustment of the MIX-BOX system.

Type	Catalog number
Hydraulic separator CPN MIX-BOX 2 with insulation (for system 2 circuits MIX-BOX)	604015
Hydraulic separator CPN MIX-BOX 3 with insulation (for system 3 circuits MIX-BOX)	604016

Set INSUL-BOX

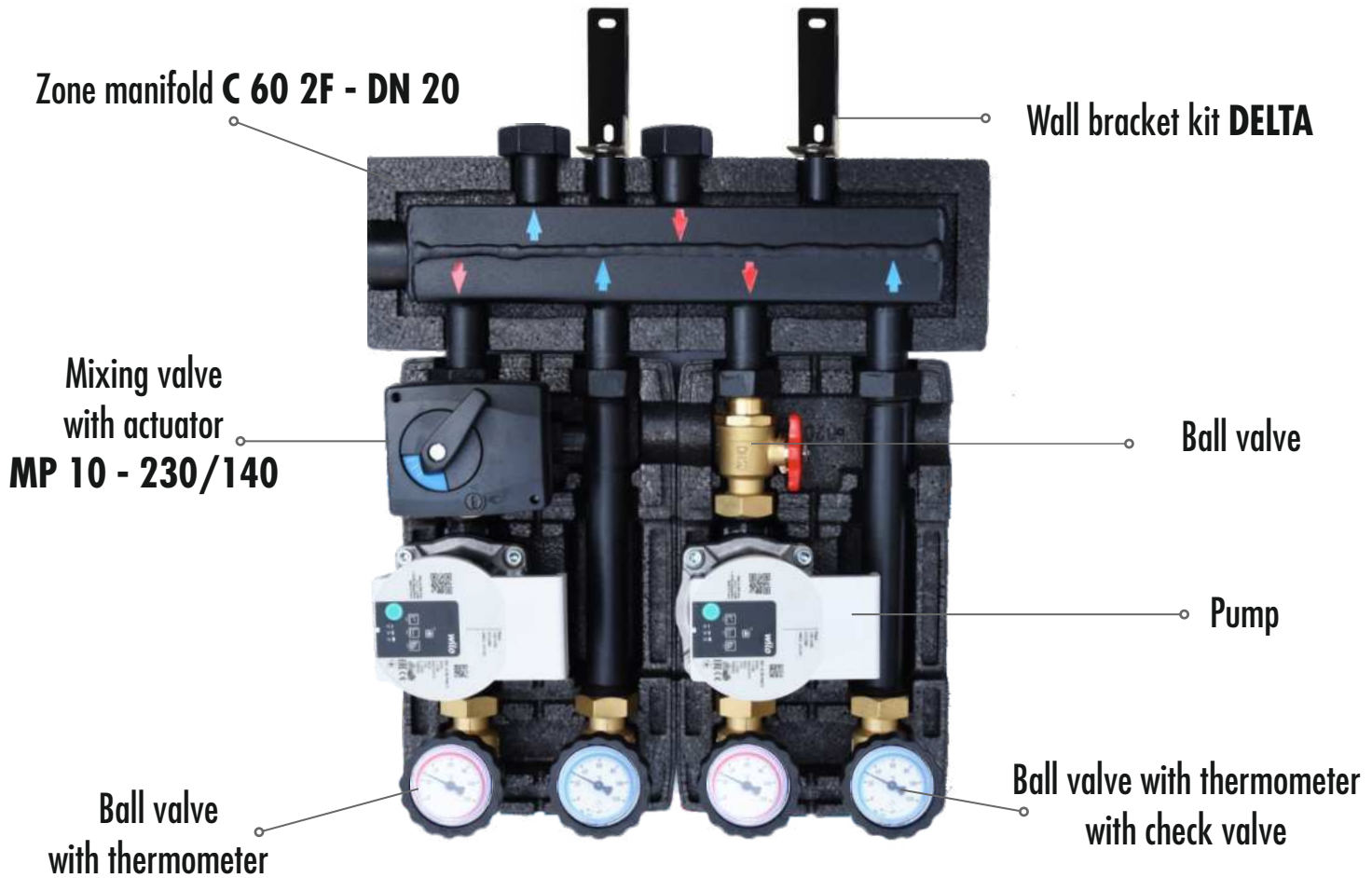

The INSUL-BOX set is a system used to support two heating circuits in installations up to 35 kW. Set contains:

- pump group SA 90 - DN 20 with ball valves,
- mixing pump group SMT 90 - DN 20 with mixing valve and MP 10 actuator,
- manifold C 60 2F - DN 20 with insulation,
- DELTA wall brackets,
- check valve

Optional

Hydraulic separator CPN 60 - DN 20

Insulated tubing kit TBN 60

Available with pumps:



Wilo Yonos Para DAB Evosta2 Grundfos UPM3



Connection options for the hydraulic separator CPN 60 - DN 20 with manifold C 60 - DN 20

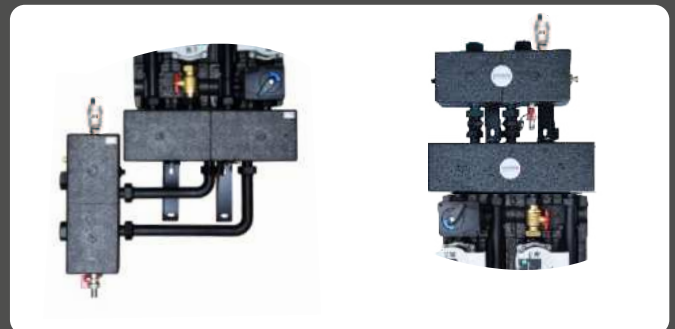

through the connector TBN 60

directly with a zone manifold

Type	Catalog number
Set INSUL-BOX DN 20 with pump Wilo Yonos Para 15/6	646001
Set INSUL-BOX DN 20 with pump Grundfos UPM3S AUTO 15 - 60	646011
Set INSUL-BOX DN 20 with pump DAB Evosta2 65/130	646021

Set MIX P

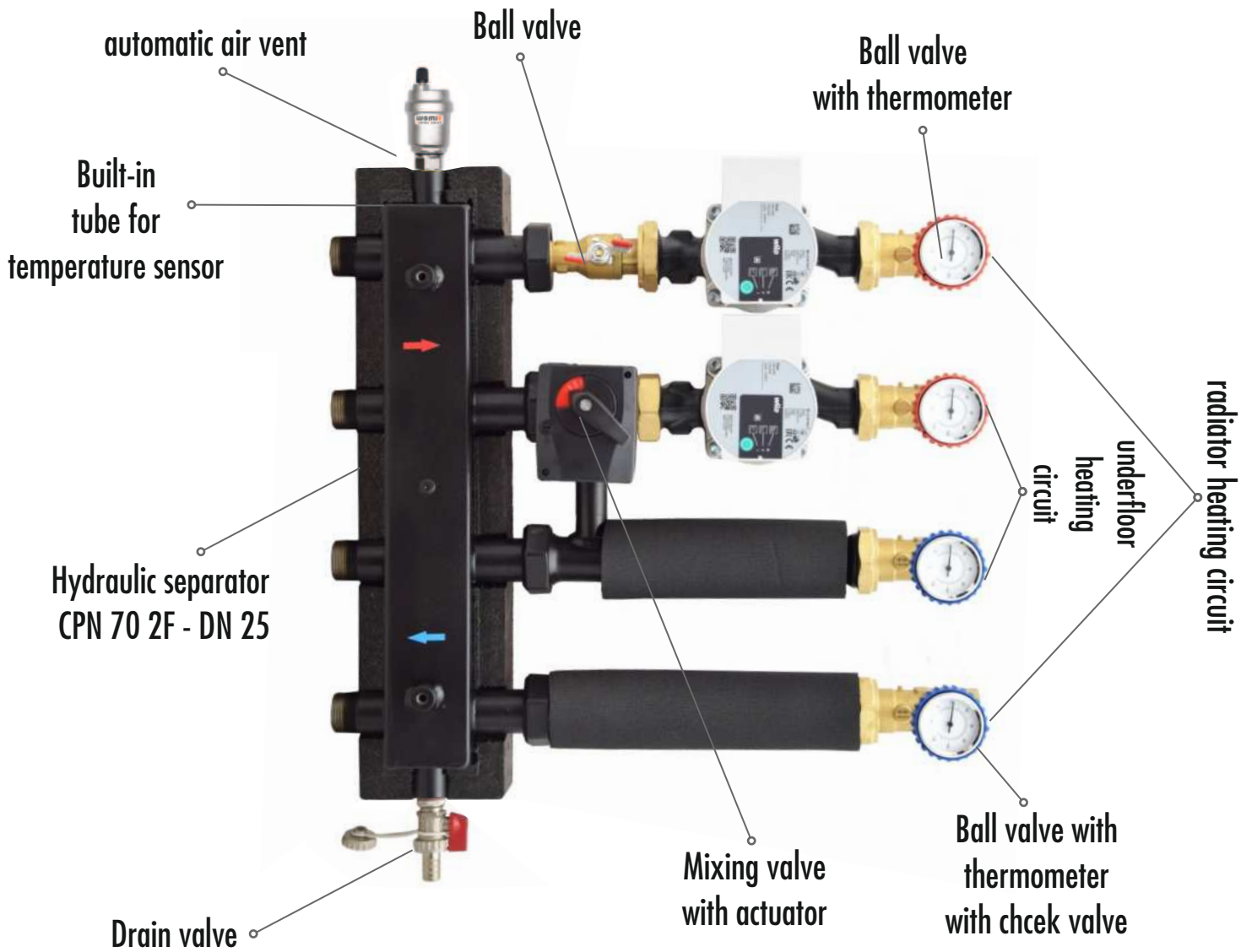

The MIX P set is a system with a hydraulic separator for operating two heating circuits in installations up to 40 kW. It comes in 3 ready variants applicable in various types of heating (see table). Each set is equipped with a hydraulic separator, pump groups with non-insulated ball valves, automatic air vent, drain valve and a built-in pipe for mounting the temperature sensor. Separator can be connected to two heat sources.

Equipment:



Available with pumps:



Wilo Yonos Para

DAB Evosta2

Grundfos UPM3

System MIX P1 System of 2 heating circuits including one with a mixing valve and a rotary electric actuator



Type	Catalog number
System MIX P1 with groups SA 125 and SMT 125 - DN25 without pumps	605100
System MIX P1 with groups SA 125 and SMT 125 - DN25 with pumps Wilo Yonos Para 25/6	605103
System MIX P1 with groups SA 125 and SMT 125 - DN25 with pumps Grundfos UPM3S AUTO 25 - 60	605104
System MIX P1 with groups SA 125 and SMT 125 - DN25 with pumps DAB Evosta2 65/180	605105

The system contains:

1. Hydraulic separator **CPN 70 2F - DN 25** with equipment,
2. Group **SA 125 - DN 25** with pump (see table),
3. Group **SMT 125 DN 25** with pump (see table),
4. Check valve,
5. Actuator **MP 10 - 230 / 140** with adapter **A 101**.

System MIX P2 System of 2 heating circuits including one with thermostatic mixing valve



Type	Catalog number
System MIX P2 with groups SA 125 and SMT1 125 - DN25 without pumps	605200
System MIX P2 with groups SA 125 and SMT1 125 - DN25 with pumps Wilo Yonos Para 25/6	605203
System MIX P2 with groups SA 125 i SMT1 125 - DN25 with pumps Grundfos UPM3S AUTO 25 - 60	605204
System MIX P2 with groups SA 125 i SMT1 125 - DN25 with pumps DAB Evosta2 65/180	605205

The system contains:

1. Hydraulic separator **CPN 70 2F - DN 25** with equipment,
2. Group **SA 125 - DN 25** with pump (see table),
3. Group **SMT1 125 DN 25** with pump (see table),
4. Check valve,

System MIX P4 System of 2 direct heating circuits without a mixing valves



Type	Catalog number
System MIX P4 with 2 groups SA 125 - DN25 without pumps	605400
System MIX P4 with 2 groups SA 125 - DN25 with pumps Wilo Yonos Para 25/6	605403
System MIX P4 with 2 grupami SA 125 - DN25 with pumps Grundfos UPM3S AUTO 25 - 60	605404
System MIX P4 with 2 grupami SA 125 - DN25 with pumps DAB Evosta2 65/180	605405

The system contains:

1. Hydraulic separator **CPN 70 2F - DN 25** with equipment,
2. Two group **SA 125 - DN 25** with pump (see table).



Type	Catalog number
Hydraulic separator CPN 70 2F - DN 25 with insulation, with equipment	606001

Set D - system of 2 heating circuits zone manifold

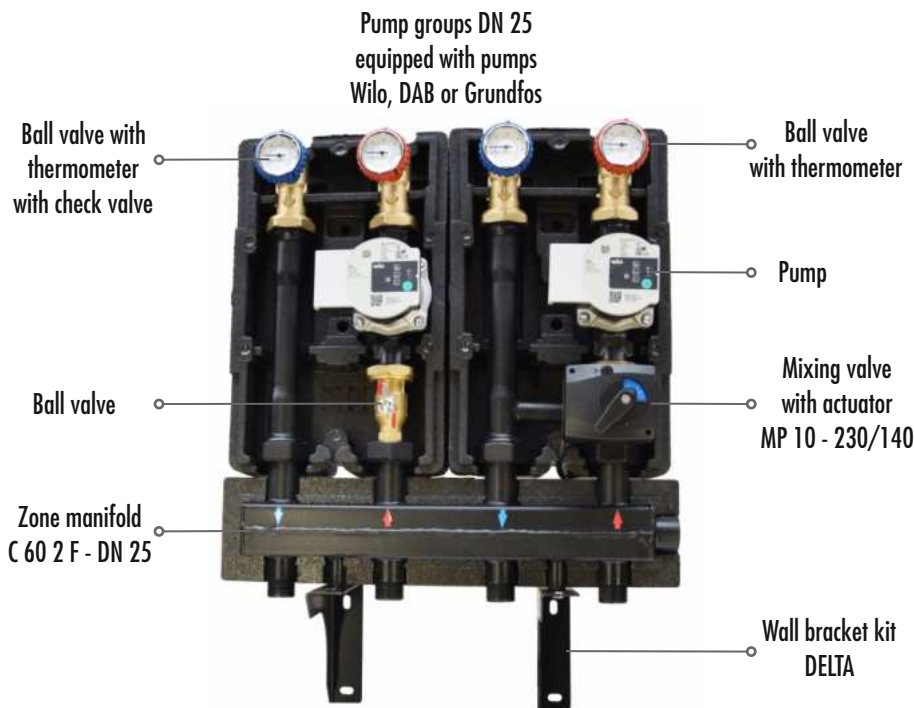

Set D is a system used to operate two heating circuits in installations up to 45 kW. The set is available in 5 pump group configurations. The system can be equipped with a hydraulic separator CPN 70 - DN 25.



Set DX - system of 2 heating circuits zone manifold with built-in hydraulic separator

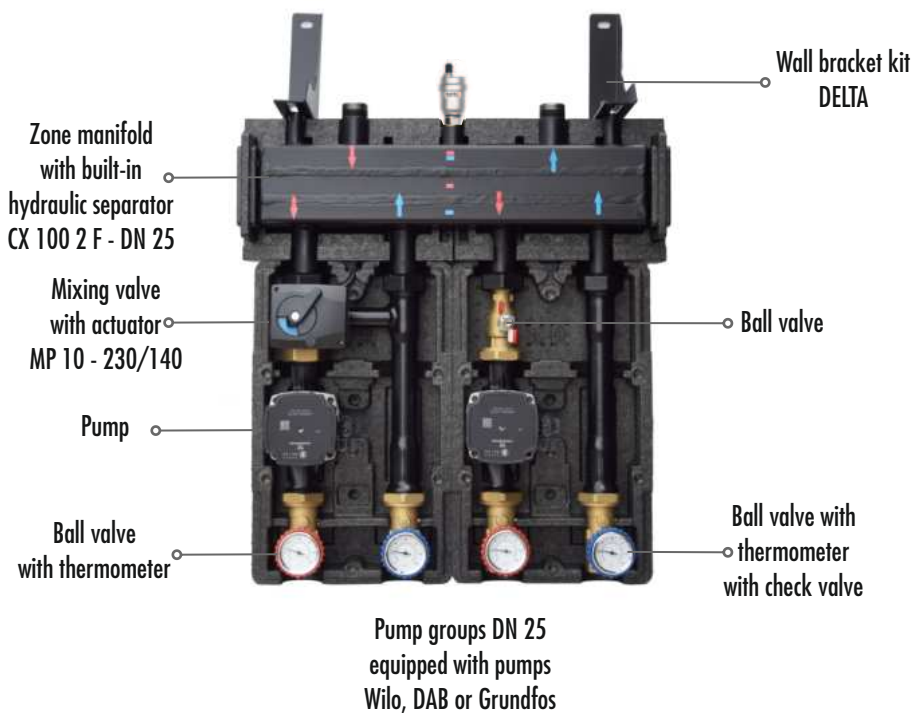

Set DX is a system used to operate two heating circuits in installations up to 55 kW. The set is available in 5 pump group configurations. Manifold with built-in hydraulic separator, equipped with a vent and a immersion sleeve for connecting a temperature sensor.

Available with pumps:



System D1 System of 2 heating circuits including one with a mixing valve and a rotary electric actuator



Type	Catalog number
Set D1 with groups SA 125 and SMT 125 - DN25 with pumps Wilo Yonos Para 25/6	656007
Set D1 with groups SA 125 and SMT 125 - DN25 with pumps Grundfos UPM3S AUTO 25 - 60	656001
Set D1 with groups SA 125 and SMT 125 - DN25 with pumps DAB Evosta2 65/180	656008

The system contains:

1. Zone manifold C 60 2 F - DN 25,
2. Group SA 125 - DN 25 with pump (see table),
3. Group SMT 125 DN 25 with pump (see table),
4. Wall bracket kit DELTA for manifold,
5. Check valve to manifold C 60 - DN 25,
6. Actuator MP 10 - 230 / 140 with adapter A 101.

System D2 System of 2 heating circuits including one with thermostatic mixing valve



Type	Catalog number
Set D2 with groups SA 125 and SMTc 125 - DN25 with pumps Wilo Yonos Para 25/6	656017
Set D2 with groups SA 125 and SMTc 125 - DN25 with pumps Grundfos UPM3S AUTO 25 - 60	656011
Set D2 with groups SA 125 and SMTc 125 - DN25 with pumps DAB Evosta2 65/180	656018

The system contains:

1. Zone manifold C 60 2 F - DN 25,
2. Group SA 125 - DN 25 with pump(see table),
3. Group SMTc1 125 - DN 25 with pump(see table),
4. Wall bracket kit DELTA for manifold,
5. Check valve to manifold C 60 - DN 25,

System D3 System of 2 heating circuits with a mixing valves and a rotary electric actuators



Type	Catalog number
Set D3 with 2 groups SMT 125 - DN25 with pumps Wilo Yonos Para 25/6	656027
Set D3 with 2 groups SMT 125 - DN25 with pumps Grundfos UPM3S AUTO 25 - 60	656021
Set D3 with 2 groups SMT 125 - DN25 with pumps DAB Evosta2 65/180	656028

The system contains:

1. Zone manifold C 60 2 F - DN 25,
2. Two group SMT 125 DN 25 with pumps (see table),
3. Wall bracket kit DELTA for manifold,
4. Two check valves to manifold C 60 - DN 25,
5. Two actuators MP 10 - 230 / 140 with adapters A 101.

System D4 System of 2 direct heating circuits without a mixing valves



Type	Catalog number
Set D4 with 2 groups SA 125 - DN25 with pumps Wilo Yonos Para 25/6	656037
Set D4 with 2 groups SA 125 - DN25 with pumps Grundfos UPM3S AUTO 25 - 60	656031
Set D4 with 2 groups SA 125 - DN25 with pumps DAB Evosta2 65/180	656038

The system contains:

1. Zone manifold C 60 2 F - DN 25,
2. Two groups SA 125 - DN 25 with pumps (see table),
3. Wall bracket kit DELTA for manifold.

System D5 - System of 2 direct heating circuits with thermostatic mixing vavles



Type	Catalog number
Set D5 with 2 groups SMTc1 125 - DN 25, with pumps Wilo Yonos Para 25/6	656047
Set D5 with 2 groups SMTc1 125 - DN 25, with pumps Grundfos UPM3S AUTO 25 - 60	656041
Set D5 with 2 groups SMTc1 125 - DN 25, with pumps DAB Evosta2 65/180	656048

The system contains:

1. Zone manifold C 60 2 F - DN 25,
2. Two groups SMTc1 125 - DN 25 with pump(see table),
3. Wall bracket kit DELTA for manifold,
4. Check valve to manifold C 60 - DN 25.

System **DX1** System of 2 heating circuits including one with a mixing valve and a rotary electric actuator



Type	Catalog number
Set DX1 with groups SA 125 and SMT 125 - DN25 with pumps Wilo Yonos Para 25/6	656107
Set DX1 with groups SA 125 and SMT 125 - DN25 with pumps Grundfos UPM3S AUTO 25 - 60	656101
Set DX1 with groups SA 125 and SMT 125 - DN25 with pumps DAB Evosta2 65/180	656108

The system contains:

1. Zone manifold **CX 100 2 F - DN 25**,
2. Group **SA 125 - DN 25** with pump (see table),
3. Group **SMT 125 DN 25** with pump (see table),
4. Wall bracket kit **DELTA** for manifold,
5. Check valve to manifold **CX 100 - DN 25**,
6. Actuator **MP 10 - 230 / 140** with adapter **A 101**.

System **DX2** System of 2 heating circuits including one with thermostatic mixing valve



Type	Catalog number
Set DX2 with groups SA 125 and SMT 125 - DN25 with pumps Wilo Yonos Para 25/6	656117
Set DX2 with groups SA 125 and SMT 125 - DN25 with pumps Grundfos UPM3S AUTO 25 - 60	656111
Set DX2 with groups SA 125 and SMT 125 - DN25 with pumps DAB Evosta2 65/180	656118

The system contains:

1. Zone manifold **CX 100 2 F - DN 25**,
2. Group **SA 125 - DN 25** with pump(see table),
3. Group **SMT 125 - DN 25** with pump(see table),
4. Wall bracket kit **DELTA** for manifold,
5. Check valve to manifold **CX 100 - DN 25**,

System **DX3** System of 2 heating circuits with a mixing valves and a rotary electric actuators



Type	Catalog number
Set DX3 with 2 groups SMT 125 - DN25 with pumps Wilo Yonos Para 25/6	656127
Set DX3 with 2 groups SMT 125 - DN25 with pumps Grundfos UPM3S AUTO 25 - 60	656121
Set DX3 with 2 groups SMT 125 - DN25 with pumps DAB Evosta2 65/180	656128

The system contains:

1. Zone manifold **CX 100 2 F - DN 25**,
2. Two group **SMT 125 DN 25** with pumps (see table),
3. Wall bracket kit **DELTA** for manifold,
4. Two chcek valves to manifold **CX 100 - DN 25**,
5. Two actuators **MP 10 - 230 / 140** with adapters **A 101**.

System **DX4** System of 2 direct heating circuits without a mixing valves



Type	Catalog number
Set DX4 with 2 groups SA 125 - DN25 with pumps Wilo Yonos Para 25/6	656137
Set DX4 with 2 groups SA 125 - DN25 with pumps Grundfos UPM3S AUTO 25 - 60	656131
Set DX4 with 2 groups SA 125 - DN25 with pumps DAB Evosta2 65/180	656138

The system contains:

1. Zone manifold **CX 100 2 F - DN 25**,
2. Two groups **SA 125 - DN 25** with pumps (see table),
3. Wall bracket kit **DELTA** for manifold.

System **DX5** - System of 2 direct heating circuits with thermostatic mixing vavles



Type	Catalog number
Set DX5 with 2 groups SMT 125 - DN 25 , with pumps Wilo Yonos Para 25/6	656147
Set DX5 with 2 groups SMT 125 - DN 25 , with pumps Grundfos UPM3S AUTO 25 - 60	656141
Set DX5 with 2 groups SMT 125 - DN 25 , with pumps DAB Evosta2 65/180	656148

The system contains:

1. Zone manifold **CX 100 2 F - DN 25**,
2. Two groups **SMT 125 - DN 25** with pump(see table),
3. Wall bracket kit **DELTA** for manifold,
4. Check valve to manifold **CX 100 - DN 25**.

Manifold with built-in hydraulic separator for 2 or 3 heating circuits **CX 100**



Manifold with built-in hydraulic separator, equipped with an air vent and an immersion sleeve for connecting a temperature sensor.

Type	Catalog number
Zone manifold with built-in hydraulic separator CX 100 2F - DN 25	636011
Zone manifold with built-in hydraulic separator CX 100 3F - DN 25	636012

Set W



The W set is a complete system for separating heating circuits in an installation with a solid fuel boiler. It can handle two heating circuits. The heating circuits can be pump or pump-mixing with a rotary mixing valve. The pump groups are equipped with a **Wilco**, **DAB** or **Grundfos** pump. The entire system is insulated.

Available with pumps:



Wilo Yonos Para



DAB Evosta2



Grundfos UPM3

Type	Catalog number
Set W without pumps	656050
Set W with pumps Wilo Yonos Para 25/6	656054
Set W with pumps Grundfos UPM3S AUTO 25-60	656052
Set W with pumps DAB Evosta2 65/180	656056

Pump group **SMR4 125 - DN 25 (1")**



Compact mixing group - **SMR4 125 - DN 25** is equipped with a 4 way mixing valve **MIX M 4-25 (kv12)**, two brass ball valves with thermometers flow and return (with built-in check valve) connector steel and insulation. On request, the group can be equipped with a pump company **Wilo**, **DAB** or **Grundfos**. In addition, to ensure automatic operation of the mixing valve should be equipped with an actuator **MP 10 - 10Nm**.

WARNING! Group is supplied with the supply to the left side. Sides can be switched.

Type	Catalog number
Group SMR4 125 - DN 25 (1") with 4-way mixing valve, without pump	606401
Group SMR4 125 - DN 25 (1") with 4-way mixing valve, with pump Wilo Yonos Para 25/6	616404
Group SMR4 125 - DN 25 (1") with 4-way mixing valve, with pump Wilo Yonos Para 25/8	616405
Group SMR4 125 - DN 25 (1") with 4-way mixing valve, with pump Grundfos UPM3S AUTO 25-60	616401
Group SMR4 125 - DN 25 (1") with 4-way mixing valve, with pump DAB Evosta2 65/180	616403

Boiler room building system up to 35 kW

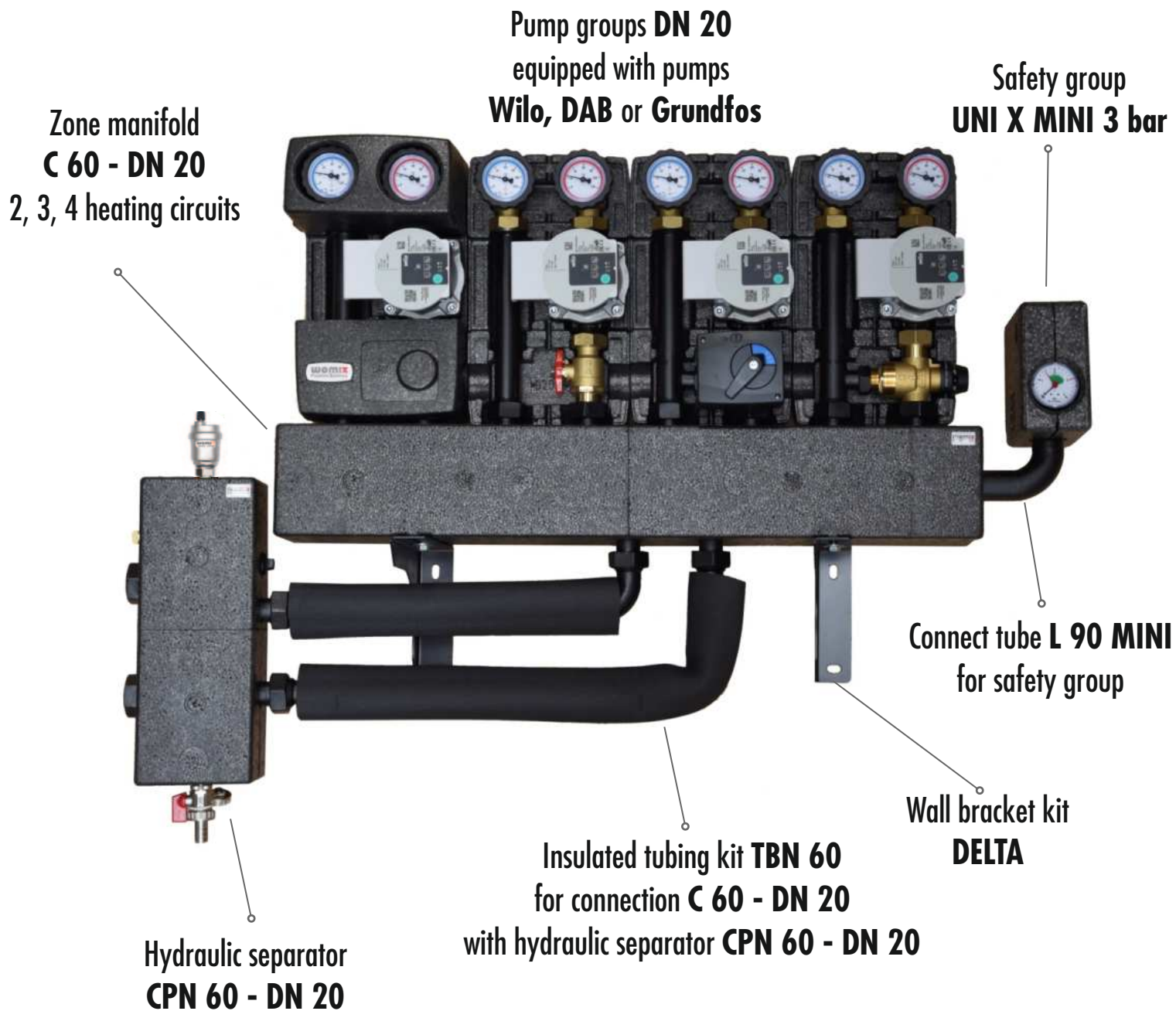

Hydraulic separator CPN 60 - DN 20 (3/4")



Hydraulic separator **CPN 60 - DN 20** is made of steel. The factory is equipped with insulation, the upper side with two connections for the temperature sensor and a vent and the lower side of the drain connection. In the set they are automatic air vent with check valve, immersion sleeve for temperature sensor and drain valve.

Type	Catalog number
Hydraulic separator CPN 60 with equipment	605002
Insulated tubing kit TBN 60/2 for connection CPN 60 - DN 20 with C 60 - DN 20	605005
Insulated tubing kit TBN 60/3 for connection CPN 60 - DN 20 with C 60 - DN 20	605006
Insulated tubing kit TBN 60/4 for connection CPN 60 - DN 20 with C 60 - DN 20	605007

Central heating zone manifold C 60 - DN 20

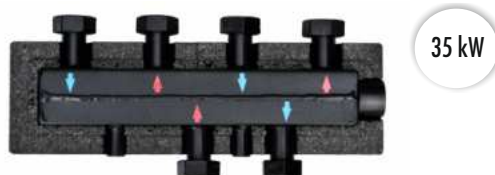

Two-chamber steel manifold **C 60**, 2, 3 or 4 zones DN 20 was created to facilitate the assembly of mixing groups. The factory manifold is equipped with EPP insulation. In addition has a DN 25 output on the supply side for connecting the safety group. On request, the manifold can be equipped with a set of mounting brackets on the wall **DELTA** (see bushings M8).

Type	Catalog number
Central heating zone manifold C 60 2 F - DN 20 with insulation	605011
Central heating zone manifold C 60 3 F - DN 20 with insulation	605012
Central heating zone manifold C 60 4 F - DN 20 with insulation	605013
Wall bracket kit DELTA for zone manifolds	606015

Additional equipment for groups DN 20



Type	Catalog number
Wall bracket kit Delta for zone manifolds	606015
Actuator MP 10	401011
Safety group 1" UNI X - MINI with safety valve 3 bar (1/2"x3/4"), automatic vent, manometer 0 - 4 bar with insulation	606021
Connect tube L 90 MINI for connection safety group UNI X MINI (73,6 kW) with manifold C 60, C 70, CN 70, CN 100	606025
Check valve for manifold Womix DN 20 - recommended when using each group with mixing valve.	606030

Pump group
SA 90 - DN 20 (3/4")



Compact pump group **SA 90 - DN 20** is equipped with three brass ball valves, two of them with supply and return water thermometers, connector with non-return valve and insulation. On request, the group can be equipped with a Wilo, Grundfos or DAB pump.

Pump group
SMT 90 - DN 20 (3/4")



The compact mixing and pump group **SMT 90 - DN 20** is equipped with a brass three-way mixing valve, two brass ball valves with supply and return water thermometers, a connector with non-return valve and insulation. On request, the group can be equipped with a Wilo, Grundfos or DAB pump. Additionally, to ensure automatic operation of the mixing valve, the group should be equipped with an **MP 10 - 10 Nm** actuator.

Pump group
SMTC 90 - DN 20 (3/4")



Compact mixing and pump group **SMTC 90 - DN 20** is equipped with thermostatic brass three-way mixing valve with temperature range 20 °C-45 °C, two brass ball valves with supply and return water thermometers, connector with non-return valve and insulation. On request, the group can be equipped with a Wilo, Grundfos or DAB pump.

Type	Catalog number
Pump group SA 90 - DN 20 (3/4") with insulation, without pump	605051
Pump group SA 90 - DN 20 (3/4") with insulation, with pump Wilo Yonos Para 15/6	605056
Pump group SA 90 - DN 20 (3/4") with insulation, with pump Grundfos UPM3S AUTO 15 - 60	605057
Pump group SA 90 - DN 20 (3/4") with insulation, with pump DAB Evosta2 65/130	605058

Type	Catalog number
Pump group SMT 90 - DN 20 (3/4") with insulation, without pump	605081
Pump group SMT 90 - DN 20 (3/4") with insulation, with pump Wilo Yonos Para 15/6	605086
Pump group SMT 90 - DN 20 (3/4") with insulation, with pump Grundfos UPM3S AUTO 15 - 60	605087
Pump group SMT 90 - DN 20 (3/4") with insulation, with pump DAB Evosta2 65/130	605088

Type	Catalog number
Pump group SMTC 90 - DN 20 (3/4") with insulation, without pump	605071
Pump group SMTC 90 - DN 20 (3/4") with insulation, with pump Wilo Yonos Para 15/6	605076
Pump group SMTC 90 - DN 20 (3/4") with insulation, with pump Grundfos UPM3S AUTO 15 - 60	605077
Pump group SMTC 90 - DN 20 (3/4") with insulation, with pump DAB Evosta2 65/130	605078

Boiler room building system up to 40 kW

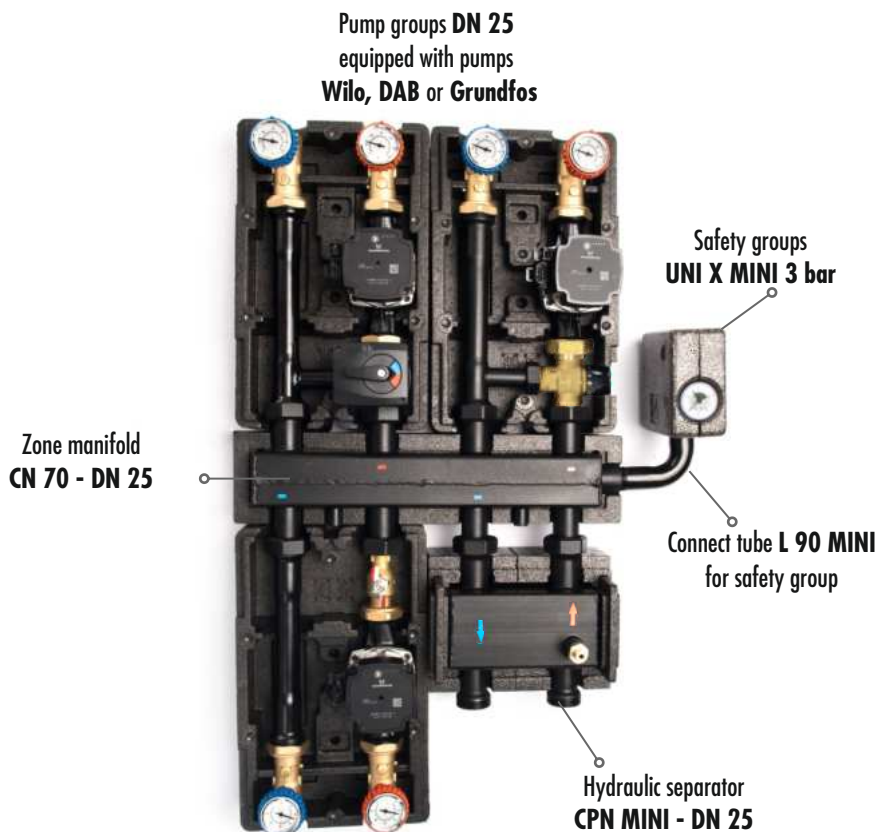

Hydraulic separator CPN MINI - DN 25 (1")

Equipment:



40 kW

2,5 m³/h

Hydraulic separator **CPN MINI - DN 25** is made of steel. The factory is equipped with insulation and connection for a temperature sensor. In the set is a immersion sleeve for temperature sensor.

Type	Catalog number
Hydraulic separator CPN MINI - DN 25 with insulation	606211

Central heating zone manifold CN 70 - DN 25



Two-chamber zone manifold **CN 70 - DN 25** was created to facilitate the assembly of pump groups. The factory manifold is equipped with EPP insulation. In addition, the manifold has a DN 25 output on the supply side for connecting the safety group. On request, the zone manifold can be equipped with a set of mounting brackets on the wall L.

WARNING! Pump groups directed downwards must have a supply side on the left (unlike the standard).

Type	Catalog number
Central heating zone manifold CN 70 2/3 F - DN 25 with insulation	606221
Central heating zone manifold CN 70 3/5 F - DN 25 with insulation	606222
Wall bracket kit L for zone manifolds CN 70	605015
Check valve for pump group with mixing valve for manifolds C 60, C70, CN 70, C 100, CN 100 - DN 25	606031

Boiler room building system up to 45 kW or 55 kW

**Pump groups DN 25
equipped with pumps
Wilo, DAB or Grundfos**

**Zone manifold
C 60 - DN 25 - up to 45 kW
or
C 70 - DN 25 - up to 55 kW**

**Safety group
UNI X MINI 3 bar**

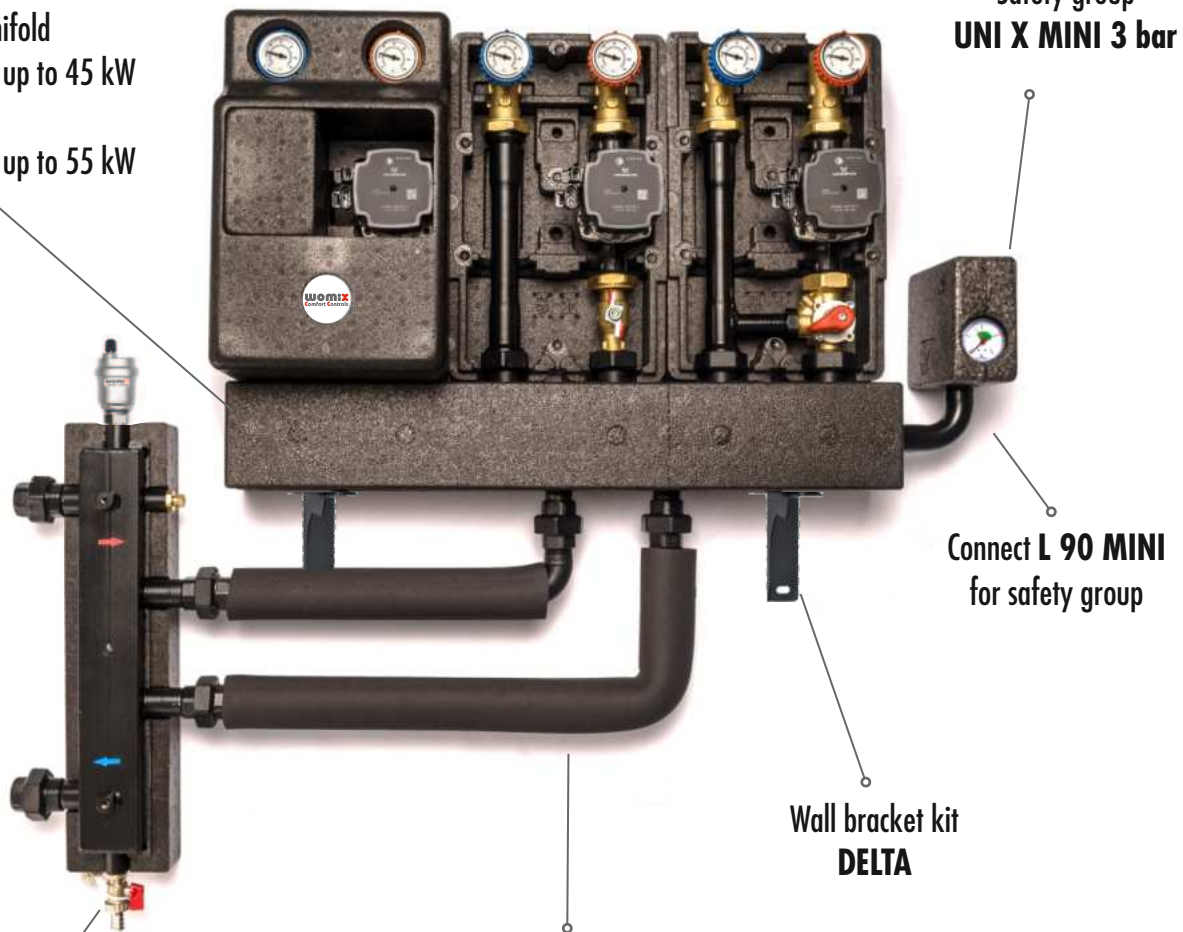

**Connect L 90 MINI
for safety group**

**Wall bracket kit
DELTA**

**Insulated tubing kit TBN 70
for connection C 60 / C 70 - DN 25
with hydraulic separator CPN 70**

**Hydraulic separator
CPN 70 - DN 25**

Hydraulic separator CPN 70 - DN 25

Equipment:



55 kW

2,5 m³/h

TBN 70
(optional)



Hydraulic separator **CPN 70** is made of steel. The factory is equipped with insulation, the upper side with two connections for the temperature sensor and a vent, and the lower side of the drain connection. In the set they are automatic air vent with check valve, immersion sleeve for temperature sensor, drain valve, four cast-iron fittings 1" and wall brackets.

Type	Catalog number
Hydraulic separator CPN 70 - DN 25 with equipment	606002
Insulated tubing kit TBN 70/2 - DN 25 for connection C 60/70 2F - DN 25 with CPN 70 - DN 25	606005
Insulated tubing kit TBN 70/3 - DN 25 for connection C 60/70 3F - DN 25 with CPN 70 - DN 25	606006
Insulated tubing kit TBN 70/4 - DN 25 for connection C 60/70 4F - DN 25 with CPN 70 - DN 25	606007

Hydraulic separator **CPN 70 - DN 25** is dedicated to pump group systems. For use outside the system, we recommend the **XP** and **XPN** series of separators

see p. 56,57

Central heating zone manifold C 60 - DN 25



45 kW

Two-chamber steel manifold **C 60 DN 25** - 2, 3 or 4 heating circuits was created to simplify installation of pump groups. The factory manifold is equipped with EPP insulation. In addition, the manifold has an output DN 20 on the return side for connecting pressure vessel and the output DN 25 on the power supply for connecting the safety group. On request, the manifold can be equipped with a set of mounting brackets on the wall **DELTA** (see bushings M8).

Type	Catalog number
Central heating zone manifold C 60 2F - DN 25 with insulation	616011
Central heating zone manifold C 60 3F - DN 25 with insulation	616012
Central heating zone manifold C 60 4F - DN 25 with insulation	616013
Wall bracket kit DELTA for zone manifolds	606015
Check valve for pump group with mixing valve for manifolds C 60, C 70, CN 70, C 100, CN 100 - DN 25	606031

Central heating zone manifold C70 - DN 25



55 kW

Two-chamber steel manifold **C 70 DN 25** - 2, 3, 4 or 5 heating circuits was created to simplify installation of pump groups. The factory manifold is equipped with EPP insulation. In addition, the manifold has an output DN 20 on the return side for connecting pressure vessel and the output DN 25 on the power supply for connecting the safety group. On request, the manifold can be equipped with a set of mounting brackets on the wall **DELTA** (see bushings M8).

Type	Catalog number
Central heating zone manifold C 70 2F - DN 25 with insulation	606011
Central heating zone manifold C 70 3F - DN 25 with insulation	606012
Central heating zone manifold C 70 4F - DN 25 with insulation	606013
Central heating zone manifold C 70 5F - DN 25 with insulation	606014
Wall bracket kit DELTA for zone manifolds	606015
Check valve for pump group with mixing valve for manifolds C 60, C 70, CN 70, C 100, CN 100 - DN 25	606031



Boiler room building system up to 73 kW

Pump groups DN 25 equipped with pumps **Wilo, DAB or Grundfos**

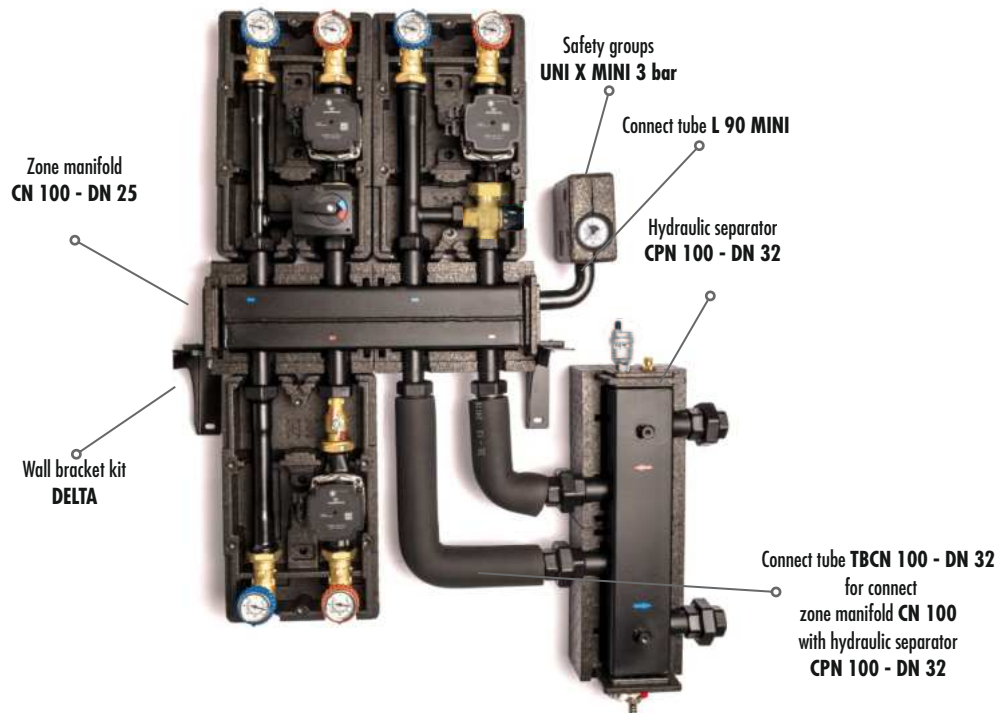

Hydraulic separator **CPN 100 - DN 32**

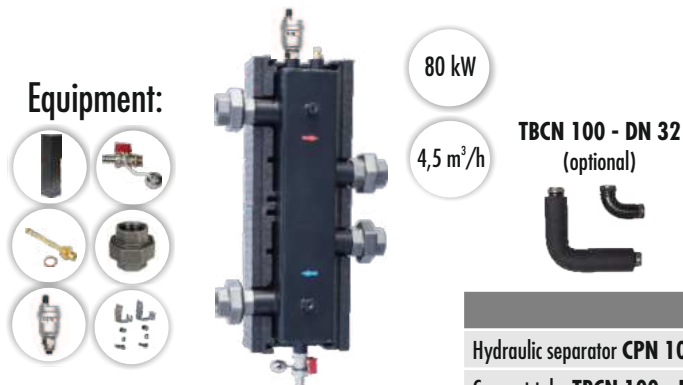

Hydraulic separator **CPN 100 DN 32** is made of steel. The factory is equipped with insulation, and the upper side with two connections for the temperature sensor and a vent, and the lower side of the drain connection. In the set they are automatic air vent with check valve, immersion sleeve for temperature sensor, four cast-iron fittings 1 1/4" and wall brackets.

Type	Catalog number
Hydraulic separator CPN 100 - DN 32 with equipment	607001
Connect tube TBCN 100 - DN 32 with insulation for connection CPN 100 - DN 32 with CN 100 - DN	617004

Central heating zone manifold **CN 100 - DN 25**



Two-chamber zone manifold **CN 100 - DN25** was created to simplify installation of pump groups. The factory manifold is equipped with EPP insulation. In addition, the manifold has a DN 25 output on the supply side for connecting the safety group. On request, the manifold can be equipped with a set of mounting brackets on the **DELTA** wall.

Type	Catalog number
Hydraulic zone manifold CN 100 2/3 F - DN 25 with insulation	626111
Hydraulic zone manifold CN 100 3/5 F - DN 25 with insulation	626112
Hydraulic zone manifold CN 100 4/7 F - DN 25 with insulation	626113
Wall bracket kit DELTA for zone manifolds	606015
Check valve for pump group with mixing valve for manifolds C 60, C 70, CN 70, C 100, CN 100 - DN 25	606031

Boiler room building system up to 80 kW

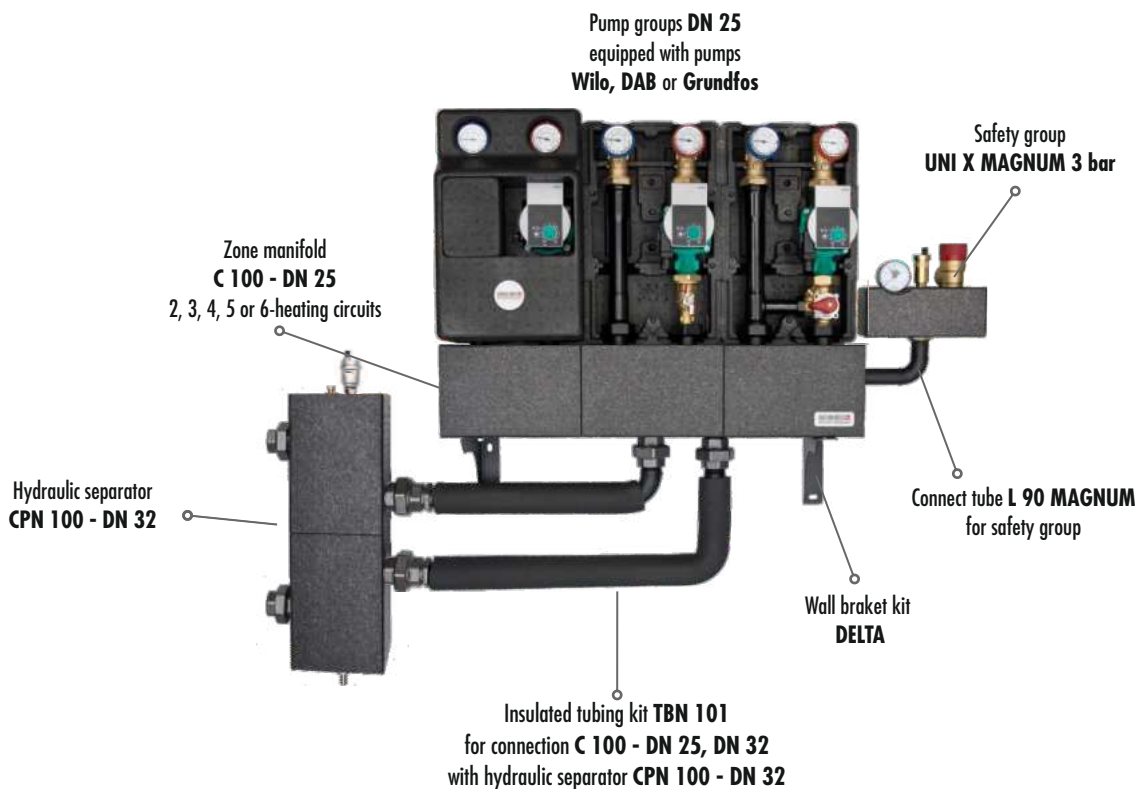

Boiler room building system up to 110 kW

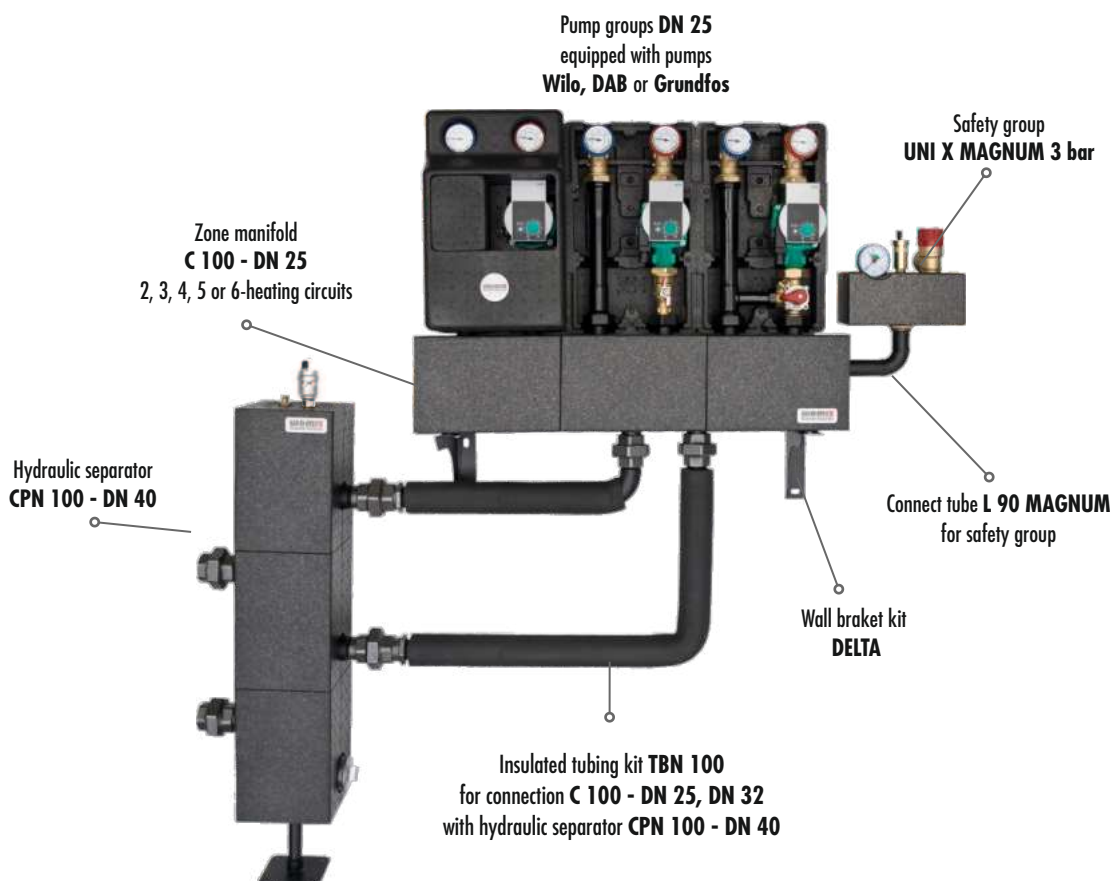

WARNING! Brackets are used instead of DELTA brackets for the C 100 6F manifold (cod.607030)



Hydraulic separator CPN 100 - DN 32 (1 1/4")

Equipment:



80 kW

4,5 m³/h

TBN 101
(optional)



Hydraulic separator **CPN 100 DN 32** is made of steel. The factory is equipped with insulation, and the upper side with two connections for the temperature sensor and a vent, and the lower side of the drain connection. In the set they are automatic air vent with check valve, immersion sleeve for temperature sensor, four cast-iron fittings 1 1/4" and wall brackets.

Type	Catalog number
Hydraulic separator CPN 100 - DN 32 with equipment	607001
Insulated tubing kit TBN 101 / 2 for connection CPN 100 - DN 32 with C 100 2F - DN 25	617005
Insulated tubing kit TBN 101 / 3 for connection CPN 100 - DN 32 with C 100 3F - DN 25	617006
Insulated tubing kit TBN 101 / 4 for connection CPN 100 - DN 32 with C 100 4F - DN 25	617007
Insulated tubing kit TBN 101 / 5 for connection CPN 100 - DN 32 with C 100 5F - DN 25	617008
Insulated tubing kit TBN 101 / 6 for connection CPN 100 - DN 32 with C 100 6F - DN 25	617009

Hydraulic separator CPN 100 - DN 40 (1 1/2")

Equipment:

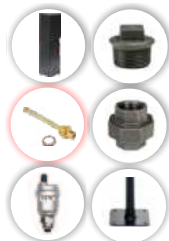

120 kW

6,5 m³/h

TBN 100
(optional)



Hydraulic separator **CPN 100 DN 40** is made of steel. The factory is equipped with insulation, and the upper side with two connections for the temperature sensor and a vent, and the lower side of the drain connection. In the set they are automatic air vent with check valve, immersion sleeve for temperature sensor, four cast-iron fittings 1 1/2" and mounting feet.

Type	Catalog number
Hydraulic separator CPN 100 - DN 40 with equipment	607002
Insulated tubing kit TBN 100/2 - DN 32 for connection CPN 100 - DN 40 with C 100 2F - DN 25	607005
Insulated tubing kit TBN 100/3 - DN 32 for connection CPN 100 - DN 40 with C 100 3F - DN 25	607006
Insulated tubing kit TBN 100/4 - DN 32 for connection CPN 100 - DN 40 with C 100 4F - DN 25	607007
Insulated tubing kit TBN 100/5 - DN 32 for connection CPN 100 - DN 40 with C 100 5F - DN 25	607008
Insulated tubing kit TBN 100/6 - DN 32 for connection CPN 100 - DN 40 with C 100 6F - DN 25	607009

Central heating zone manifold C 100 - DN 25 (1")



Two-chamber steel manifold **C 100 DN 25 - 2, 3, 4, 5 or 6** heating circuits was created to simplify installation of pump groups. The factory manifold is equipped with EPP insulation. In addition, the manifold has an output DN 20 on the return side for connecting pressure vessel and the output DN 25 on the power supply for connecting the safety group. On request, the manifold can be equipped with a set of mounting brackets on the wall **DELTA** (see bushings M8).

Warning! The exception is the manifold **C 100 6F**. The above-mentioned manifold can be equipped with a set of mounting brackets on the floor (cod.607030).

Type	Catalog number
Central heating zone manifold C 100 2F - DN 25 with insulation	626011
Central heating zone manifold C 100 3F - DN 25 with insulation	626012
Central heating zone manifold C 100 4F - DN 25 with insulation	626013
Central heating zone manifold C 100 5F - DN 25 with insulation	626014
Central heating zone manifold C 100 6F - DN 25 with insulation	626015
Brackets for mounting manifold C 100 6F - DN 25/DN 32 on the floor (1set. = 2 pcs)	607030
Wall bracket kit DELTA for zone manifolds	606015
Check valve for pump group with mixing valve for manifolds C 60, C 70, CN 70, C 100, CN 100 - DN 25	606031

Pump group SA 125 - DN 25 (1") - without mixing valve



Compact pump group **SA 125 - DN 25** is equipped with three brass ball valves including two with thermometers on supply and return (with built-in check valve) steel connector and insulation. On request, the group can be equipped with a pump **Wilo, DAB** or **Grundfos**.

WARNING! Group comes from the supply side to the right. Sides can be switched.

Pump group SMT 125 - DN 25 (1") - with rotary mixing valve



Compact mixing group **SMT 125 - DN 25** is equipped with a brass three-way mixing valve **MIX MT 25**, two brass ball valves with thermometers supply and return (with built-in check valve) steel connector and insulation. On requests group can be equipped with a pump **Wilo, DAB** or **Grundfos**. Additionally to ensure automatic operation of the mixing valve must be equipped with an actuator **MP 10 - 10 Nm**.

WARNING! Group comes from the supply side to the right. Sides can be switched.

Pump group SMTc 125 - DN 25 (1") - with thermostatic mixing valve



Compact thermostatic mixing group **SMTc 125 - DN 25** is equipped with a thermostatic mixing valve brass three-way **MIX THERM** (kv 3,4) for regulating the temperature of 20 - 45 °C or 35-60°C (depending on the model of the group), two thermometers supply and return (with built-in check valve) steel connector and insulation. On request, the group can be equipped with a pump **Wilo, DAB** or **Grundfos**.

WARNING! Group comes from the supply side to the right. Sides can be switched.

Type	Catalog number
Pump group SA 125 - DN 25 with insulation, without pump	606051
Pump group SA 125 - DN 25 with insulation, with pump Wilo Yonos Para 25/6	616054
Pump group SA 125 - DN 25 with insulation, with pump Wilo Yonos Para 25/8	616055
Pump group SA 125 - DN 25 with insulation, with pump Grundfos UPM3S AUTO 25-60	616056
Pump group SA 125 - DN 25 with insulation, with pump DAB Evosta2 65/180	616057

Type	Catalog number
Pump group SMT 125 - DN 25 with insulation, without pump	606081
Pump group SMT 125 - DN 25 with insulation, with pump Wilo Yonos Para 25/6	616084
Pump group SMT 125 - DN 25 with insulation, with pump Wilo Yonos Para 25/8	616085
Pump group SMT 125 - DN 25 with insulation, with pump Grundfos UPM3S AUTO 25-60	616086
Pump group SMT 125 - DN 25 with insulation, with pump DAB Evosta2 65/180	616087

Type	Catalog number SMTc1 20-45°C	Catalog number SMTc2 35-60°C
Pump group SMTc 125 - DN 25 with insulation, without pump	606071	606091
Pump group SMTc 125 - DN 25 with insulation, with pump Wilo Yonos Para 25/6	616074	616094
Pump group SMTc 125 - DN 25 with insulation, with pump Wilo Yonos Para 25/8	616075	616095
Pump group SMTc 125 - DN 25 with insulation, with pump Grundfos UPM3S AUTO 25-60	616076	616096
Pump group SMTc 125 - DN 25 with insulation, with pump DAB Evosta2 65/180	616077	616097



Boiler room building system up to 80 kW

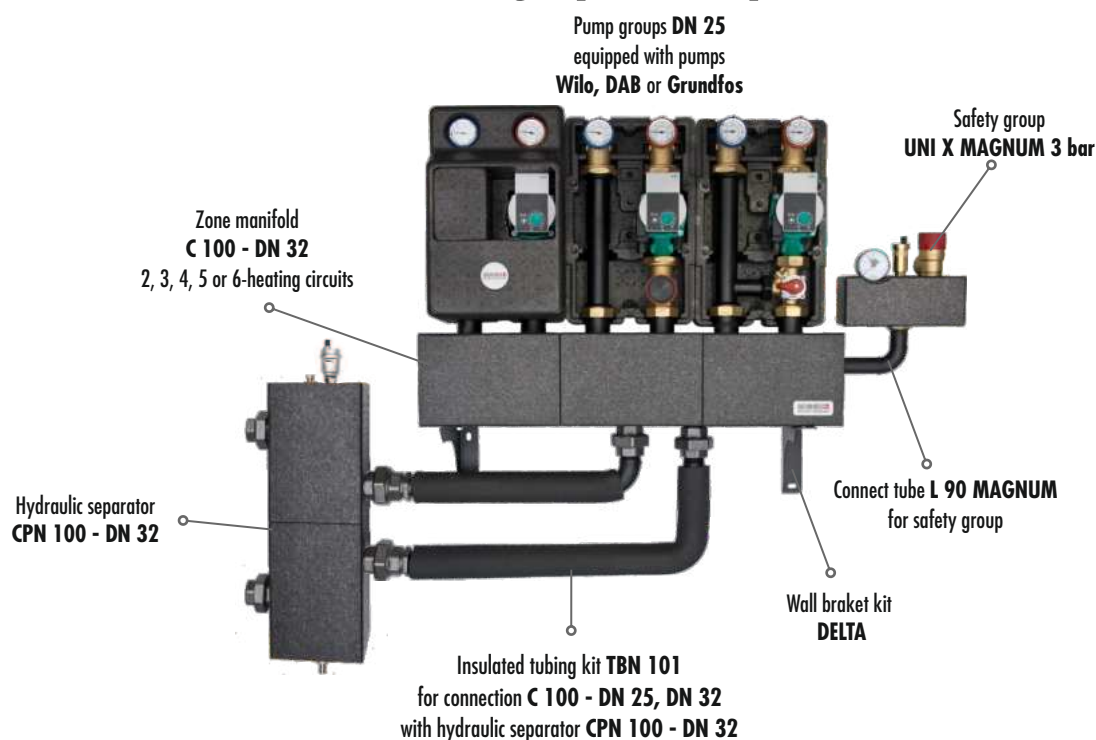

Boiler room building system up to 120 kW

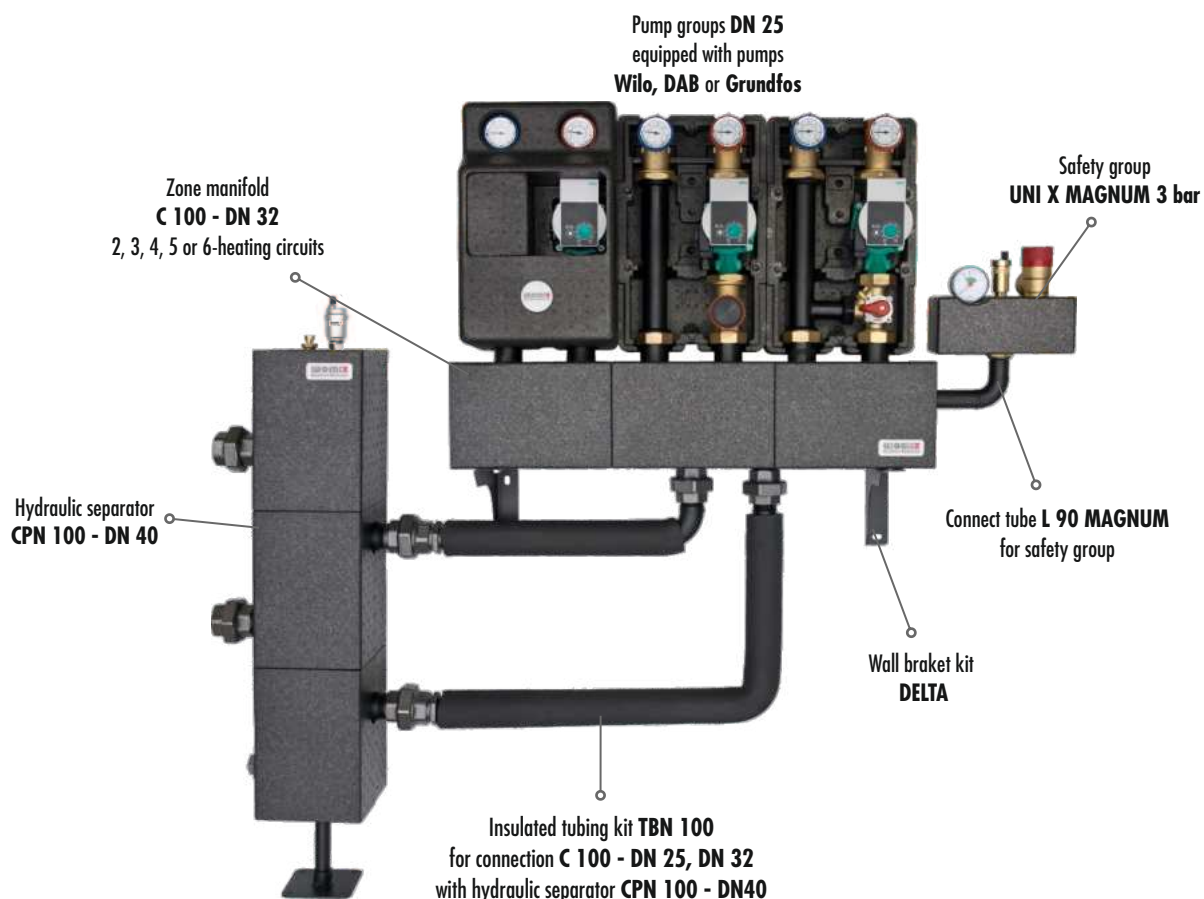

WARNING! Brackets are used instead of DELTA brackets for the C 100 6F manifold (cod. 607030)

Hydraulic separator CPN 100 - DN 32 (1 1/4")

Equipment:



80 kW

4,5 m³/h

TBN 101
(optional)



Hydraulic separator **CPN 100 DN 32** is made of steel. The factory is equipped with insulation, and the upper side with two connections for the temperature sensor and a vent, and the lower side of the drain connection. In the set they are automatic air vent with check valve, immersion sleeve for temperature sensor, four cast-iron fittings 1 1/4" and wall brackets.

Type	Catalog number
Hydraulic separator CPN 100 - DN 32 with equipment	607001
Insulated tubing kit TBN 101 / 2 for connection CPN 100 - DN 32 with C 100 2F - DN 32	617005
Insulated tubing kit TBN 101 / 3 for connection CPN 100 - DN 32 with C 100 3F - DN 32	617006
Insulated tubing kit TBN 101 / 4 for connection CPN 100 - DN 32 with C 100 4F - DN 32	617007
Insulated tubing kit TBN 101 / 5 for connection CPN 100 - DN 32 with C 100 5F - DN 32	617008
Insulated tubing kit TBN 101 / 6 for connection CPN 100 - DN 32 with C 100 6F - DN 32	617009

Hydraulic separator CPN 100 - DN 40 (1 1/2")

Equipment:

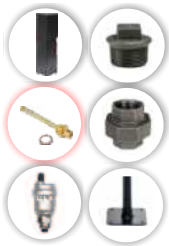

120 kW

6,5 m³/h

TBN 100
(optional)



Hydraulic separator **CPN 100 DN 40** is made of steel. The factory is equipped with insulation, and the upper side with two connections for the temperature sensor and a vent, and the lower side of the drain connection. In the set they are automatic air vent with check valve, immersion sleeve for temperature sensor, four cast-iron fittings 1 1/2" and mounting feet.

Type	Catalog number
Hydraulic separator CPN 100 - DN 40 with equipment	607002
Insulated tubing kit TBN 100/2 - DN 32 for connection CPN 100 - DN 40 with C 100 2F - DN 32	607005
Insulated tubing kit TBN 100/3 - DN 32 for connection CPN 100 - DN 40 with C 100 3F - DN 32	607006
Insulated tubing kit TBN 100/4 - DN 32 for connection CPN 100 - DN 40 with C 100 4F - DN 32	607007
Insulated tubing kit TBN 100/5 - DN 32 for connection CPN 100 - DN 40 with C 100 5F - DN 32	607008
Insulated tubing kit TBN 100/6 - DN 32 for connection CPN 100 - DN 40 with C 100 6F - DN 32	607009

Central heating zone manifold C 100 - DN 32



Two-chamber steel manifold **C 100 DN 32 - 2, 3, 4, 5 or 6** heating circuits was created to simplify installation of pump groups DN 32. The factory manifold is equipped with EPP insulation. In addition, the manifold has an output DN 20 on the boiler side for connecting pressure vessel and the output DN 25 on the installation side for connecting the safety group. On request, the manifold can be equipped with a set of mounting brackets on the wall **DELTA** (see bushings M8).

Warning! In order to connect the DN 32 group to the manifold it is necessary to buy additional connections DN 1 1/4" x 2" or connections with integrated ball valve (see below).

Warning! The exception is the manifold C 100 6F. The above-mentioned manifold can be equipped with a set of mounting brackets on the floor (cod.607030).

Type	Catalog number
Central heating zone manifold C 100 2F - DN 32 with insulation	607011
Central heating zone manifold C 100 3F - DN 32 with insulation	607012
Central heating zone manifold C 100 4F - DN 32 with insulation	607013
Central heating zone manifold C 100 5F - DN 32 with insulation	607014
Central heating zone manifold C 100 6F - DN 32 with insulation	607015
Brackets for mounting manifold C 100 6F - DN 25/DN 32 on the floor (1set. = 2 pcs)	607030
Wall bracket kit DELTA for zone manifolds	606015
Reduction for mounting groups DN 25 on manifold C 100 DN 32, C2 100 - DN 32 - set = 2 pcs.	607023
Connection DN 1 1/4" x 2" with brass nut - 1 pc	607016
Connection DN 1 1/4" x 2" with built-in ball valve, with brass nut - 1 pc	607017
Connection DN 1 1/4" x 2" with brass nut, with check valve for groups SMT, SMT C - 1 pc	607018

Boiler room building system up to 220 kW

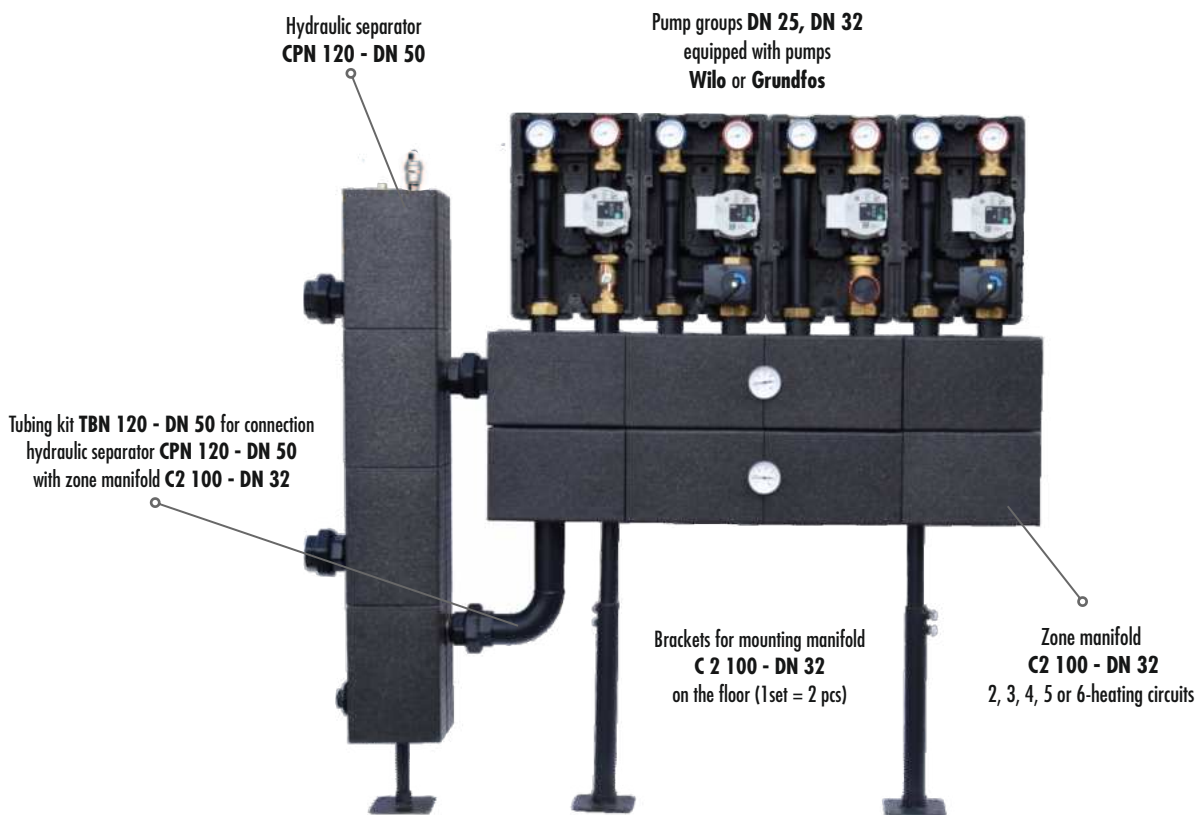

Central heating zone manifold C 2 100 - DN 32



Two-chamber steel manifold **C2 100 DN 32** - 2, 3, 4, 5 or 6 heating circuits was created to simplify installation of pump groups. The factory manifold is equipped with EPP insulation. Additional manifold is equipped with two thermometers and two the socket 1/2 " F drain.

Warning! In order to connect the DN 32 group to the manifold it is necessary to buy additional connections DN 1 1/4 "x 2" or connections with integrated ball valve (see below).

Type	Catalog number
Central heating zone manifold C2 100 2F - DN 32 with insulation	607041
Central heating zone manifold C2 100 3F - DN 32 with insulation	607042
Central heating zone manifold C2 100 4F - DN 32 with insulation	607043
Central heating zone manifold C2 100 5F - DN 32 with insulation	607044
Central heating zone manifold C2 100 6F - DN 32 with insulation	607045
Brackets for mounting manifold on the floor (1 set = 2 pcs)	607040
Reduction mounting groups DN 25 on manifold C 100 DN 32, C2 100 - DN 32 - set - 2 pcs.	607023
Connection DN 1 1/4" x 2" with brass nut	607016
Connection with built-in ball valve DN 1 1/4" x 2" with brass nut	607017
Connection DN 1 1/4" x 2" with brass nut , with check valve for groups SMT	607018

Hydraulic separator CPN 120 - DN 50 (2")



220 kW
9,5 m³/h



Hydraulic separator **CPN 120** is made of steel. The factory is equipped with insulation, and the upper side with two connections for the temperature sensor and a vent, and the lower side of the drain connection. In the set they are automatic air vent with check valve, immersion sleeve for temperature sensor, four cast-iron fittings 2" and mounting feet.

Type	Catalog number
Hydraulic separator CPN 120 - DN 50 with equipment	609001
Connect tube TBN 120 - DN 50 for connection C2 100 - DN 32 with CPN 120 - DN 50	609005

Additional equipment for pump groups systems DN 25/DN 32



Type	Catalog number
Wall bracket kit DELTA for zone manifolds	606015
Actuator MP 10	401011
Safety group 1" UNI X - MINI (73,6 kW) with safety valve. 3 bar (1/2"x3/4"), automatic vent, manometer 0 - 4 bar, with insulation EPP.	606021
Safety group 1" UNI X - MAGNUM (200 kW) with safety valve. 3 bar (1"x1 1/4"), automatic vent, manometer 0 - 4 bar, with insulation EPP.	606022
Connect tube L90 for connection group UNI X - MINI (73,6 kW) with manifold C 60, C 70, CN 70, CN 100 - DN 25	606025
Connect tube L90 for connection group UNI X - MAGNUM (200 kW) with manifold C 100, C2 100	606027
Connect tube S for connection vessel with manifold C 60, 70 - DN - 25	606026
Check valve for pump group with mixing valve for manifolds C 60, C 70, CN 70, C 100, CN 100 - DN 25	606031
Brackets for mounting manifold C 100 6F - DN 25/DN 32 on the floor (1set. = 2 pcs)	607030
Brackets for mounting manifold C 2 100 - DN 32 and C 100 6F 32 on the floor (1set. = 2 pcs)	607040
Reduction mounting groups DN 25 on manifold C 100 DN 32, C2 100 - DN 32 - set - 2 pcs.	607023
Connection DN 1 1/4" x 2" with brass nut	607016
Connection DN 1 1/4" x 2" with built-in ball valve, with brass nut.	607017
Connection DN 1 1/4" x 2" with brass nut, with check valve for mixing group SMT	607018

Pump group SA 125 - DN 32 (1 1/4") - without mixing valve



Compact pump group SA 125 - DN 32 is equipped with three brass ball valves including two with thermometers supply and return (with built-in check valve) steel connector and insulation. On request, the group can be equipped with a pump **Grundfos** or **Wilo**.

WARNING! Group comes from the supply side to the right. Sides can be switched.

Pump group SMT 125 - DN 32 (1 1/4") - with rotary mixing valve



Compact mixing group SMT 125 - DN 32 is equipped with a brass three-way mixing valve **MIX MT 32**, two brass ball valves with thermometers supply and return (with built-in check valve) steel connector and insulation. On requests group can be equipped with a pump **Grundfos** or **Wilo**. Additionally to ensure automatic operation of the mixing valve must be equipped with an actuator **MP 10 - 10 Nm**.

WARNING! Group comes from the supply side to the right. Sides can be switched.

Type	Catalog number
Pump group SA 125 - DN 32 (1 1/4") with insulation, without pump	607051
Pump group SA 125 - DN 32 (1 1/4") with insulation, with pump Wilo Yonos Para 30/6	607158
Pump group SA 125 - DN 32 (1 1/4") with insulation, with pump Wilo Yonos Para 30/8	607159
Pump group SA 125 - DN 32 (1 1/4") with insulation, with pump Grundfos Alpha 1 L 32-60	607055

Type	Catalog number
Pump group SMT 125 - DN 32 (1 1/4") with insulation, without pump	607061
Pump group SMT 125 - DN 32 (1 1/4") with insulation, with pump Wilo Yonos Para 30/6	607066
Pump group SMT 125 - DN 32 (1 1/4") with insulation, with pump Wilo Yonos Para 30/8	607067
Pump group SMT 125 - DN 32 (1 1/4") with insulation, with pump Grundfos Alpha 1 L 32-60	607065

Hydraulic separator CPN 120 - DN 65 (2 1/2")



Hydraulic separator **CPN 120 – DN 65** is made of steel. The factory is equipped with insulation, the upper side have two connections for the temperature sensor and a vent, and the lower side of the drain connection. In the set they are automatic air vent with check valve, immersion sleeve for temperature sensor, four cast-iron fittings 2 ½" and mounting feet.

Technical data:

Max pressure:	8 bar
Flow rate:	18 m ³ /h
Max temp.	110°C
Insulation material:	EPP black 40 g/l
Connections:	2 ½"

Type	Catalog number
Hydraulic separator CPN 120 - DN 65 with equipment	609002
Connect tube TBN 120 - DN 65 for connection CPN 120 - DN 65 with C 2 120 - DN 50	609006

Central heating zone manifold C 2 120 - DN 50



Two-chamber steel manifold **C2 120 DN 50** – 2 or 3 heating circuits was created to simplify installation of pump groups DN 25, DN 32, DN 40, DN 50. The factory manifold is equipped with EPP insulation. Additional manifold is equipped with two thermometers and two the socket ½" F drain.

Technical data:

Max pressure:	6 bar
Max temp.:	110°C
Max. power:	350 kW (ΔT 20°C)
Axle spacing:	Installation side: 250 mm
Connections:	Installation side: 2" M Boiler side: 2 ½"
Insulation material:	EPP black 40 g/l

Type	Catalog number
Central heating zone manifold C 2 120 2 F - DN 50 with insulation	609011
Central heating zone manifold C 2 120 3 F - DN 50 with insulation	609012
Brackets for mounting manifold on the floor (1 set = 2 pcs)	607040

Send us a boiler room project or development guidelines, and we will prepare for you quote with visualization.

Connector spacer application proposal (page 53) in the case of using a Y-strainer

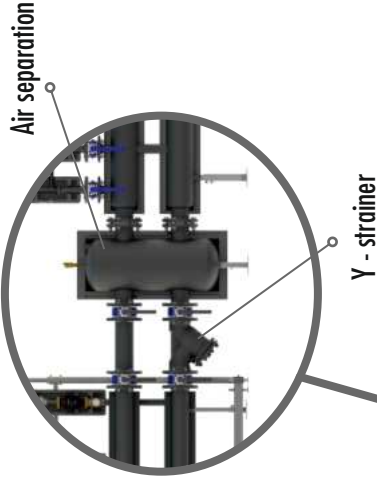

Can be mounted directly hydraulic separator with a zone manifold



Frame assembly RK

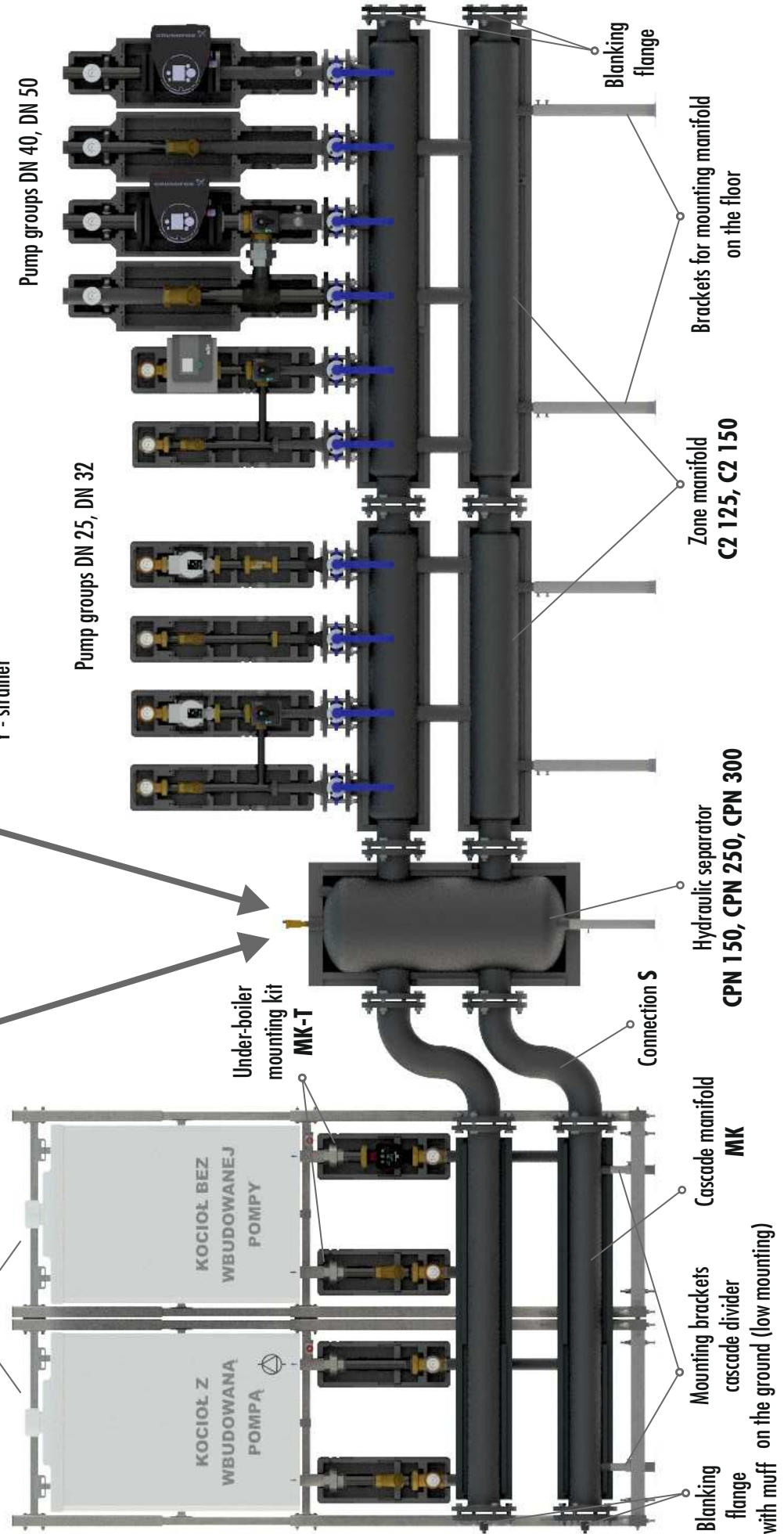

Boiler connections DN 32, DN 40



Schematic drawing of the boiler connection to the cascade distributor

Boiler connections DN 32, DN 40 have been designed to facilitate the connection of the boiler with a Womix cascade manifold. They have 1 1/4" or 1 1/2" male thread outputs (depending on the model) and a cast iron nut on the boiler side. Additionally, one of the connections has a 1/2" socket for connecting the drain valve (included).

Type	Catalog number
MK-T under-boiler assembly kit - DN 32 (price per set)	610830
MK-T under-boiler assembly kit - DN 40 (price per set)	610840

Cascade manifold MK 65, MK 80, MK 100, MK 125



Two-chamber steel cascade manifolds MK 65, MK 80, MK 100, MK 125 are designed to connect two or more heat sources. They are factory-equipped with EPP insulation. After sending the request, the manifold is adjusted to the designed boiler (any size of the spacing and connections from the boiler side is possible)

Type	Power at $\Delta T 20^{\circ}C$	Flow [m ³ /h]	Catalog number
Cascade manifold MK 65 2 F - DN 50 two-circuit module with insulation	120,00	6,00	610102
Cascade manifold MK 65 3 F - DN 50 three-circuit module with insulation	120,00	6,00	610103
Cascade manifold MK 65 2 F - DN 65 two-circuit module with insulation	210,00	9,00	610202
Cascade manifold MK 65 3 F - DN 65 three-circuit module with insulation	210,00	9,00	610203
Cascade manifold MK 80 2 F - DN 80 two-circuit module with insulation	280,00	12,00	610302
Cascade manifold MK 80 3 F - DN 80 three-circuit module with insulation	280,00	12,00	610303
Cascade manifold MK 100 2 F - DN 100 two-circuit module with insulation	470,00	20,00	610402
Cascade manifold MK 100 3 F - DN 100 three-circuit module with insulation	470,00	20,00	610403
Cascade manifold MK 125 2 F - DN 125 two-circuit module with insulation	700,00	30,00	610502
Cascade manifold MK 125 3 F - DN 125 three-circuit module with insulation	700,00	30,00	610503
Brackets for mounting manifold on the floor (1set. = 2 pcs)			607040
Brackets for mounting cascade manifold on the floor (1set. = 2 pcs) - low assembly			607050

S connector for connecting a cascade zone manifolds with hydraulic separator



The connectors are made of steel. They are designed to reduce the installation height of the cascade manifold. The set includes one connector and a set of 4 assembly screws with a gasket.

Type	Catalog number
Connector S - DN 50 for connecting a cascade manifold with hydraulic separator CPN 150 - DN 50	699040
Connector S - DN 65 for connecting a cascade manifold with hydraulic separator CPN 250 - DN 65	699041
Connector S - DN 80 for connecting a cascade manifold with hydraulic separator CPN 250 - DN 80	699042
Connector S - DN 100 for connecting a cascade manifold with hydraulic separator CPN 300 - DN 100	699043
Connector S - DN 125 for connecting a cascade manifold with hydraulic separator CPN 300 - DN 125	699044

Hydraulic separator CPN 150, CPN 250, CPN 300



**Mounting feet
included**

The CPN 250, CPN 300 hydraulic separator is made of steel. The factory is equipped in EPP insulation and from the upper side with two connections for a temperature sensor (socket 1 ") and a vent (socket 1 ¼"), and from the bottom with a drain (socket 1 ¼"). Hydraulic separator contains a system of built-in meshes (1.) and baffles (2.) to help precipitate air bubbles and sediments, thus increasing its functionality and efficiency. It is included in the set mounting foot.

Technical data:	
Maximum pressure:	6 bar
Maximum temperature:	110 C
Maximum flow:	6-30 m ³ /h (depending on the model)
Insulation:	EPP black 40 g/l
Heating power:	120-700 kW (depending on the model)
Flange pressure standard:	PN 16

Type	Power at ΔT 20°C	Flow [m ³ /h]	Volume [l]	Catalog number
Hydraulic separator CPN 150 - DN 50 with insulation	120,00	6,00	9	609100
Hydraulic separator CPN 250 - DN 65 with insulation	210,00	9,00	26	609101
Hydraulic separator CPN 250 - DN 80 with insulation	280,00	12,00	26	609102
Hydraulic separator CPN 300 - DN 100 with insulation	470,00	20,00	61	609103
Hydraulic separator CPN 300 - DN 125 with insulation	700,00	30,00	62	609104

Central heating zone manifold C2 100 - DN 50



Two-chamber steel manifold C 2 100 - DN 50 2 or 3-circuit DN 50 was created to facilitate the installation of pump groups DN 25, 32. The factory is equipped with EPP insulation, 2 gaskets with a diameter adapted to the diameter of the manifold connection and a set of 8 assembly screws for connecting with another manifold or hydraulic clutch.

C2 100 - DN 50 manifolds are adapted to the assembly of DN 25, DN 32 groups with a spacing of 125 mm.

The manifold can be combined with the C2 125 - DN 50 manifold, making it possible to use pump groups with spacings of 125 mm and 250 mm in one boiler room.

Type	Power at ΔT 20°C	Flow [m ³ /h]	Catalog number
Zone manifold C2 100 2 F - DN 50 with insulation,	120,00	6,00	609112
Zone manifold C2 100 3 F - DN 50 with insulation,	120,00	6,00	609113
Reduction mounting groups DN 25 on manifold C 100 DN 32, C2 100 - DN 32 - set - 2 pcs.			607023
Connection DN 1 1/4" x 2" with brass nut			607016
Connection DN 1 1/4" x 2" with built-in ball valve, with brass nut.			607017
Connection DN 1 1/4" x 2" with brass nut, with check valve for mixing group SMT			607018
Brackets for mounting manifold on the floor (1 set = 2 pcs)			607040
Pump groups DN 25, DN 32			Page 39 and 44

Central heating zone manifold C2 125, C2 150



The two-chamber steel manifold C 2 125, C 2 150, 2 or 3 circuit was created to facilitate the assembly of pump groups DN 25, 32, 40, 50. The factory is equipped with EPP insulation and has a DN 50 flange connection on the installation side. The manifold contains 2 gaskets with a diameter adapted to the diameter of the manifold connection and a set of 8 mounting screws to connect with another manifold or hydraulic separator. We can make manifolds on request with a different connection.

Technical data:

Raw material:

Max pressure: 6 bar

Max temp.: 110 °C

Power: 120-700 kW at ΔT 20 °C

Insulation material: EPP black 40 g/l

Type	Power at ΔT 20°C	Flow [m ³ /h]	Catalog number
Central heating zone manifold C 2 125 2 F - DN 50 with insulation	120,00	6,00	609119
Central heating zone manifold C 2 125 3 F - DN 50 with insulation	120,00	6,00	609120
Central heating zone manifold C 2 125 2 F - DN 65 with insulation	210,00	9,00	609121
Central heating zone manifold C 2 125 3 F - DN 65 with insulation	210,00	9,00	609122
Central heating zone manifold C 2 125 2 F - DN 80 with insulation	280,00	12,00	609123
Central heating zone manifold C 2 125 3 F - DN 80 with insulation	280,00	12,00	609124
Central heating zone manifold C 2 150 2 F - DN 100 with insulation	470,00	20,00	609125
Central heating zone manifold C 2 150 3 F - DN 100 with insulation	470,00	20,00	609126
Central heating zone manifold C 2 150 2 F - DN 125 with insulation	700,00	30,00	609127
Central heating zone manifold C 2 150 3 F - DN 125 with insulation	700,00	30,00	609128
Type			Catalog number
Brackets for mounting manifold on the floor (1 set = 2 pcs)			607040

Pump group **D-SA 250 - DN 25, DN 32**
- without mixing valve



Compact pump group **D-SA 250 - DN 25, 32** is equipped with three ball valves, including two with thermometers, one with non-return valve, oblique filter, steel connectors and insulation. On request, the group can be equipped with a Wilo, DAB or Grundfos pump. To connect the group with the **C 2 125, C 2 150** manifold, two connections DN 50 should be purchased - see accessories.

Pump group **D-SMT 250 - DN 25, DN 32**
- with rotary mixing valve



Compact pump group **D-SMT 250 - DN 25, 32** equipped with two ball valves with thermometers, including one with non-return valve, **MIX-MT** rotary mixing valve, oblique filter, steel connectors and insulation. On request, the group can be equipped with a Wilo, DAB or Grundfos pump. To connect the group with the **C 2 125, C 2 150** manifold, two connections DN 50 should be purchased - see accessories. Additionally, to ensure automatic operation of the mixing valve, the group should be equipped with an **MP 10 - 10Nm** actuator.

Type	Catalog number
Pump group D-SA 250 - DN 25 (1") with insulation, without pump	609051
Pump group D-SA 250 - DN 25 (1") with insulation, with pump Wilo Yonos Para 25/6	609054
Pump group D-SA 250 - DN 25 (1") with insulation, with pump Wilo Yonos Para 25/8	609055
Pump group D-SA 250 - DN 25 (1") with insulation, with pump Grundfos UPM3S AUTO 25-60	609053
Pump group D-SA 250 - DN 25 (1") with insulation, with pump DAB Evosta2 65/180	609058

Type	Catalog number
Pump group D-SA 250 - DN 32 (1 1/4") with insulation, without pump	619051
Pump group D-SA 250 - DN 32/25 (1 1/4") with insulation, without pump, with connection for a threaded pump DN 25 (180 mm)	619058
Pump group D-SA 250 - DN 32 (1 1/4") with insulation, with pump Wilo Yonos Para 30/6	619054
Pump group D-SA 250 - DN 32 (1 1/4") with insulation, with pump Wilo Yonos Para 30/8	619055
Pump group D-SA 250 - DN 32 (1 1/4") with insulation, with pump Grundfos Alpha 1L 32 - 60	619053

Type	Catalog number
Pump group D-SMT 250 - DN 25 (1") with insulation, without pump	649051
Pump group D-SMT 250 - DN 25 (1") with insulation, with pump Wilo Yonos Para 25/6	649054
Pump group D-SMT 250 - DN 25 (1") with insulation, with pump Wilo Yonos Para 25/8	649055
Pump group D-SMT 250 - DN 25 (1") with insulation, with pump Grundfos UPM3S AUTO 25-60	649053
Pump group D-SMT 250 - DN 25 (1") with insulation, with pump DAB Evosta2 65/180	649058

Type	Catalog number
Pump group D-SMT 250 - DN 32 (1 1/4") with insulation, without pump	659051
Pump group D-SMT 250 - DN 32/25 (1 1/4") with insulation, without pump, without pump, with connection for a threaded pump DN 25 (180 mm)	659058
Pump group D-SMT 250 - DN 32 (1 1/4") with insulation, with pump Wilo Yonos Para 30/6	659054
Pump group D-SMT 250 - DN 32 (1 1/4") with insulation, with pump Wilo Yonos Para 30/8	659055
Pump group D-SMT 250 - DN 32 (1 1/4") with insulation, with pump Grundfos Alpha 1L 32 - 60	659053

Type	Catalog number
Connection DN 50 (Flange) x 1" (Nut G 1 1/2") - to connect groups DN 25 with zone manifolds	699001
Connection DN 50 (Flange) x 1" (Nut G 1 1/2") with check valve - to connect groups DN 25 with zone manifolds	699002
Connection DN 50 (Flange) x 1 1/4" (Nut G 2") - to connect groups DN 32 with zone manifolds	699003
Connection DN 50 (Flange) x 1 1/4" (Nut G 2") with check valve - to connect groups DN 32 with zone manifolds	699004

Pump group D-SA 250 - DN 40, DN 50



Compact pump group **D-SA 250 - DN 40, 50** is equipped with a set of steel connectors, oblique filter, two thermometers and additional outputs 1/2" GW on the power supply and return and isolation.

Technical data:

Maximum pressure:	6 bar
Maximum temperature:	110 °C
Wheelbase:	250 mm
Seals:	VITON or EPDM
Connection: boiler side:	flange DN 50, PN 16
installation side:	M 1 1/2" for D-SA 250 - DN 40 M 2" for D-SA 250 - DN 50

ATTENTION! The pump group is not equipped with shut-off valves. We recommend the installation of standard commercially available products, i.e. ball valves on the installation side, DN 50 dampers on the boiler side.

Type	Catalog number
Group D-SA 250 - DN 40 (1 1/2") with insulation, without pump, pump installation length 250mm	629052
Group D-SA 250 - DN 40/32 (1 1/2") with insulation, without pump, with connection for a threaded pump DN 32 (180 mm)	629059
Group D-SA 250 - DN 40/25 (1 1/2") with insulation, without pump, with connection for a threaded pump DN 25 (180 mm)	629058
Set of distance extensions RG 40 250 mm / 220 mm for the installation of DN 40 pumps with a length of 220 mm - price per set. - 2 pcs.	629090
Type	Catalog number
Grupa D-SA 250 - DN 50 (2") with insulation, without pump, pump installation length 280mm	639052
Grupa D-SA 250 - DN 50/40 (2") with insulation, without pump, with connection for a flanged pump DN 40 (250 mm)	639057
Grupa D-SA 250 - DN 50/32 (2") with insulation, without pump, with connection for a threaded pump DN 32 (180 mm)	639059
Grupa D-SA 250 - DN 50/25 (2") with insulation, without pump, with connection for a threaded pump DN 25 (180 mm)	639058
Set of distance extensions RG 50 280 mm / 240 mm for installation of DN 50 pumps with a construction length of 240 mm - price per set. - 2 pcs.	629091

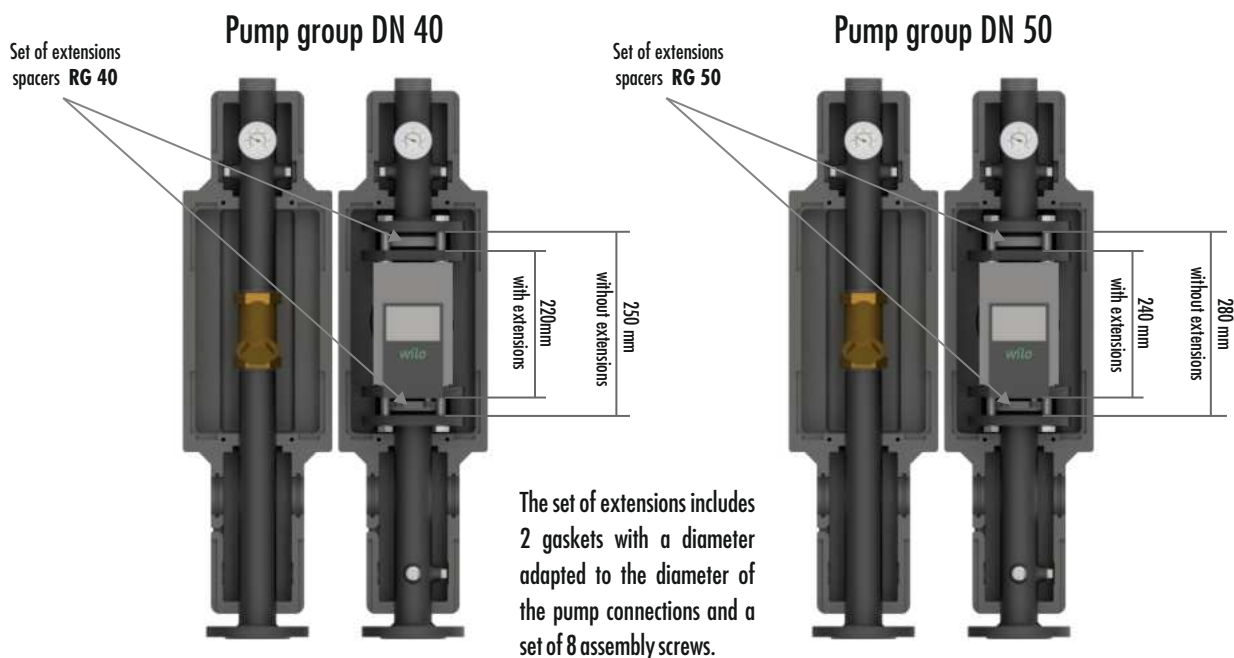

Pump group D-SMT 250 - DN 40, DN 50



Compact mixing and pump group **D-SMT 250 - DN 40, 50** is equipped with a set of steel connectors, check valve, oblique filter, mixing valve MIX M, two thermometers and additional outputs 1/2 "GW on the supply and return and insulation. Additionally, to ensure automatic operation of the mixing valve, the group should be equipped with an **MP 10 - 10 Nm** actuator.

Technical data:

- Maximum pressure: 6 bar
- Maximum temperature: 110 °C
- Wheelbase: 250 mm
- Seals: VITON or EPDM
- Connection: boiler side: flange DN 50, PN 16
- installation side: M 1 1/2 "for D-SMT 250 - DN 40
M 2 "for D-SMT 250 - DN 50

ATTENTION! The pump group is not equipped with shut-off valves. We recommend the installation of standard commercially available products, i.e. ball valves on the installation side, DN 50 dampers on the boiler side.

Type	Catalog number
Group D-SMT 250 - DN 40 (1 1/2 ") with insulation, without pump, pump installation length 250mm	669052
Group D-SMT 250 - DN 40 (1 1/2 ") with insulation, without pump, with connection for a threaded pump DN 32 (180 mm)	669059
Group D-SMT 250 - DN 40 (1 1/2 ") with insulation, without pump, with connection for a threaded pump DN 25 (180 mm)	669058
Set of distance extensions RG 40 250 mm / 220 mm for the installation of DN 40 pumps with a length of 220 mm - price per set. - 2 pcs.	629090
Type	Catalog number
Group D-SMT 250 - DN 50 (2 ") with insulation, without pump, pump installation length 280mm	679052
Group D-SMT 250 - DN 50 (2 ") with insulation, without pump, with connection for a flanged pump DN 40 (250 mm)	679057
Group D-SMT 250 - DN 50 (2 ") with insulation, without pump, with connection for a threaded pump DN 32 (180 mm)	679059
Group D-SMT 250 - DN 50 (2 ") with insulation, without pump, with connection for a threaded pump DN 25 (180 mm)	679058
Set of distance extensions RG 50 280 mm / 240 mm for installation of DN 50 pumps with a construction length of 240 mm - price per set. - 2 pcs.	629091

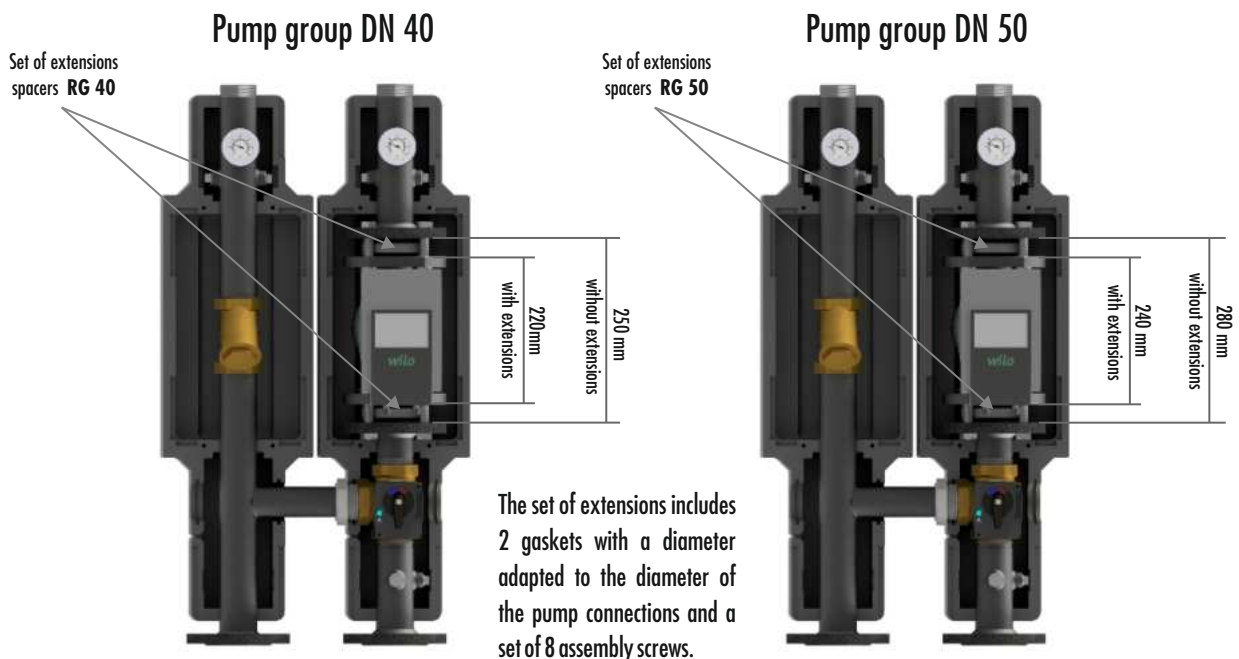

System accessories up to 700 kW

Brackets for mounting manifold on the floor



Actuator MP



Connector distance



Angle connector 90° DN 50, 65, 80, 100, 125



Connection DN 50 (Flange) x (Nut G 2")



Blanking flanges



Type	Catalog number
Actuator MP 10	401011
Brackets for mounting manifold on the floor (1 set = 2 pcs)	607040
Brackets for mounting cascade manifold on the floor (1 set = 2 pcs)	607050
Angle connector 90° - DN 50 with 4 mounting screws and a gasket EPDM DN 50	699010
Angle connector 90° - DN 65 with 4 mounting screws and a gasket EPDM DN 65	699011
Angle connector 90° - DN 80 with 4 mounting screws and a gasket EPDM DN 80	699012
Angle connector 90° - DN 100 with 4 mounting screws and a gasket EPDM DN 100	699013
Angle connector 90° - DN 125 with 4 mounting screws and a gasket EPDM DN 125	699014
Connection DN 50 (Flange) x 1" (Nut G 1 1/2") - to connect groups DN 25 with zone manifolds	699001
Connection DN 50 (Flange) x 1" (Nut G 1 1/2") with check valve - to connect groups DN 25 with zone manifolds	699002
Connection DN 50 (Flange) x 1 1/4" (Nut G 2") - to connect groups DN 32 with zone manifolds	699003
Connection DN 50 (Flange) x 1 1/4" (Nut G 2") with check valve - to connect groups DN 32 with zone manifolds	699004
Blanking flange DN 50 with 4 mounting screws and a gasket EPDM DN 50	699020
Blanking flange DN 65 with 4 mounting screws and a gasket EPDM DN 65	699021
Blanking flange DN 80 with 4 mounting screws and a gasket EPDM DN 80	699022
Blanking flange DN 100 with 4 mounting screws and a gasket EPDM DN 100	699023
Blanking flange DN 125 with 4 mounting screws and a gasket EPDM DN 125	699024
Blanking flange with muff DN 50 with 4 mounting screws and a gasket EPDM DN 50	699030
Blanking flange with muff DN 65 with 4 mounting screws and a gasket EPDM DN 65	699031
Blanking flange with muff DN 80 with 4 mounting screws and a gasket EPDM DN 80	699032
Blanking flange with muff DN 100 with 4 mounting screws and a gasket EPDM DN 100	699033
Blanking flange with muff DN 125 with 4 mounting screws and a gasket EPDM DN 125	699034
Connector distance DN 50 (L-230) with 4 mounting screws and a gasket EPDM DN 50	699050
Connector distance DN 65 (L-290) with 4 mounting screws and a gasket EPDM DN 65	699051
Connector distance DN 80 (L-310) with 4 mounting screws and a gasket EPDM DN 80	699052
Connector distance DN 100 (L-350) with 4 mounting screws and a gasket EPDM DN 100	699053
Connector distance DN 125 (L-400) with 4 mounting screws and a gasket EPDM DN 125	699054
Butterfly valve	page 58

Heat pump or air conditioner WM stand / bracket

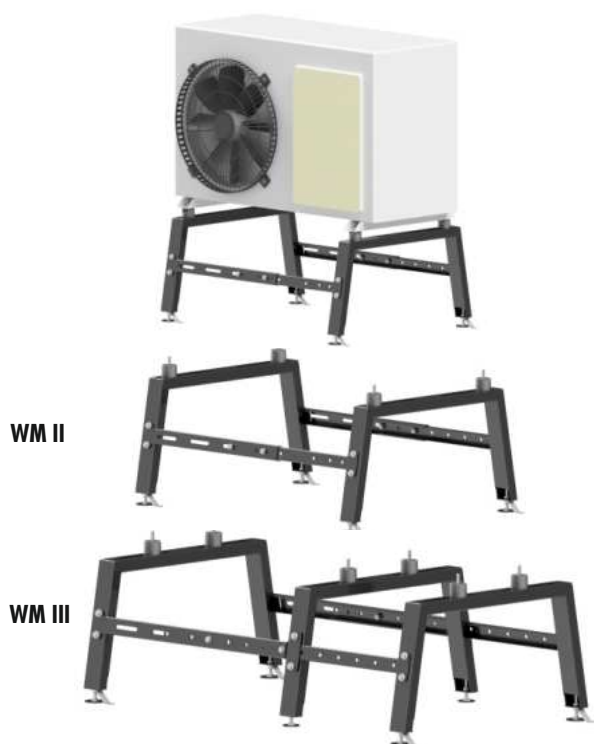

The stands (supports) WM II and WM III intended for heat pumps or air conditioners are made of steel. The stability of the stand has been increased by the use of adjustment fasteners on both sides. The design of the stand guarantees that it can be used with any heat pump or air conditioner. The brackets are equipped with vibration isolators to catch vibrations of the device and feet, together with a handle that allows the stand to be anchored. The bracket with the device should be placed on a permanently leveled base that can carry five times the weight of the device. Possible unevenness can be eliminated by a foot with an adjusting screw.

Set contains:

- Steel elements of the stand
- Vibro-isolators with nuts
- Adjustable feet with the possibility of anchoring to the ground
- Mounting screws

In case of doubts about the matching of the WM stand to the device being used, please contact us by e-mail at export@womix.pl.

Type	Catalog number
Heat pump or air conditioner stand / bracket WM II 42/92	610951
Heat pump or air conditioner stand / bracket WM II 52/92	610955
Heat pump or air conditioner stand / bracket WM II 52/135	610956
Heat pump or air conditioner stand / bracket WM III 42/135	610962

Mounting frame for the RK wall-hung boiler



The mounting frame is designed to facilitate the installation of hanging boilers. To connect the two frames you need a set of bolts and plates. Frame in white.

Due to the different width of the boilers, their mounting and the need to adapt the frame to the spacing of the manufacturer's chimney systems, please send data of the boiler used (name / catalog card) in order to prepare a frame suitable for the boiler.

Type	Catalog number
Mounting frame for the RK wall-hung boiler (one frame = one boiler)	610910
A set of screws and sheets for joining two RK assembly frames	610900

Magnetic filter with strainer FM

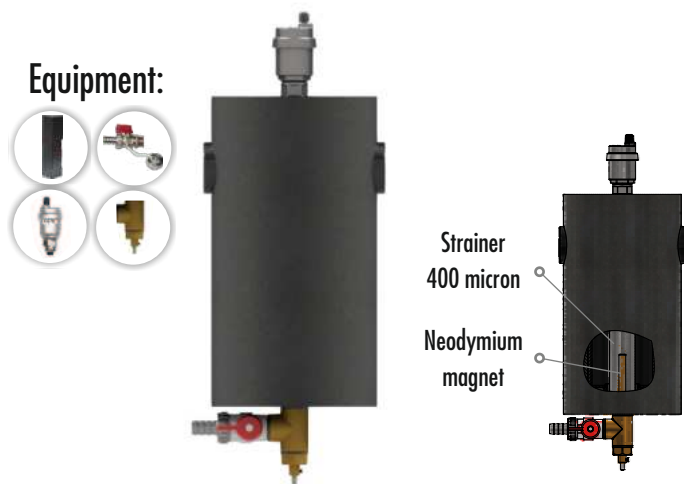

The **FM** magnetic filter is a device designed to trap solid pollutants carried by water in central heating installations, heating networks, heat centers, boiler rooms, as well as in glycol installations in air-conditioning systems. Their use allows for the proper operation of heat exchangers, pumps, boilers and other system devices, preventing the deposition of impurities that remain in the desilter and are easy to remove. Contrary to systems without a filter separator, the sedimentation of sludge and limescale effectively reduces the efficiency of devices operating in such conditions. This is especially important for heat exchangers.

Advantages of using a magnetic filter with strainer:

- securing and significantly reducing the risk of damage to the installation and its components,
- silencing the operation of the installation,
- exceptional simple removal of the separator contamination, removal of contamination without the need to shut down the installation.

Type	Catalog number
Magnetic filter with strainer FM 65 - DN 25 with insulation, with equipment	611091
Magnetic filter with strainer FM 80 - DN 32 with insulation, with equipment	611092
Magnetic filter with strainer FM 100 - DN 40 with insulation, with equipment	611093
Magnetic filter with strainer FM 150 - DN 50 with insulation, with equipment	611094

Hydraulic separator XP 80 ELEC, XP 100 ELEC



Equipment:



Flow heating tube HP 100 - DN 40



Equipment:



Hydraulic separator **XP 80 ELEC** and **XP 100 ELEC** for heating systems is made of steel. Factory equipped with an automatic air vent, a immersion sleeve for connecting a temperature sensor and EPP insulation and thermometer.

Attention! The product does not contain a heater.

Flow heating tube **HP 100 - DN 40** for heating installations is made of steel. The factory is equipped with an automatic air vent, EPP insulation and thermometer.

Attention! The product does not contain a heater.

Attention! To prevent damage to the heater during operation, a constant flow of medium through the device must be ensured.

Type	Catalog number
Hydraulic separator XP 80 - DN 32 ELEC with insulation, with equipment	609305
Hydraulic separator XP 100 - DN 40 ELEC with insulation, with equipment	609306
Flow heating tube HP 100 - DN 40 with insulation, with equipment	609310



Hydraulic separators

Hydraulic separator CPN 70 2F - DN 25 (1") - for 2 heat sources

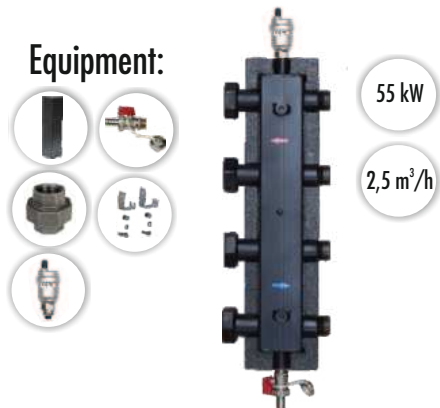

Hydraulic separator **CPN 70 2F - DN 25** is made of steel. It is factory-equipped into insulation, on the upper side into a connection for a vent and a built-in pipe for the temperature sensor, and on the lower side into a drain connection. The set includes air vent with check valve, drain valve, four 1" cast iron fittings and wall brackets.

Hydraulic separator CPN 100 2F - DN 32 (1 1/4") - for 2 heat sources

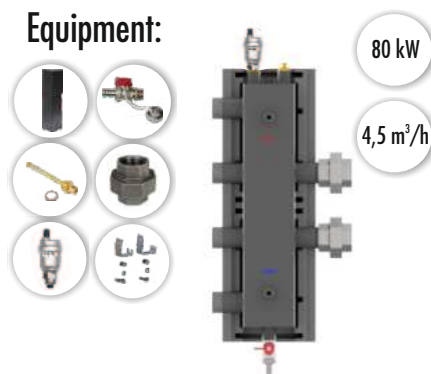

Hydraulic separator **CPN 100 2F - DN 32** is made of steel. The factory is equipped with insulation, on the upper side with two connections for a temperature sensor and a vent and on the lower side with a drain connection. Included There are a air vent with check valve, a plunger sleeve for connecting a temperature sensor, a drain valve, two 1 1/4 " cast iron fittings and wall brackets.

Hydraulic separator CPN 100 2F - DN 40 (1 1/2") - for 2 heat sources

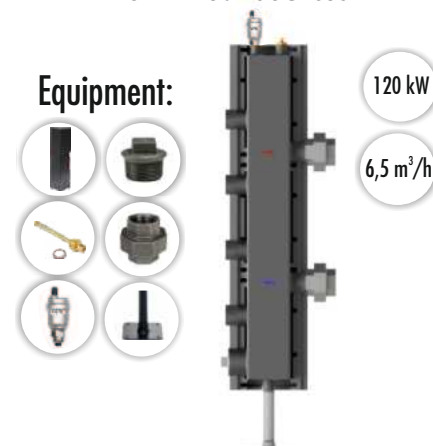

Hydraulic separator **CPN 100 2F - DN 40** is made of steel. The factory is equipped with insulation, on the upper side with two connections for a temperature sensor and a vent and on the lower side with a drain connection . The set includes a air vent with check valve, plunger sleeve for connecting a temperature sensor, two 1 1/2 " cast iron screw connections and a mounting foot.

Type	Catalog number
Hydraulic separator CPN 70 2F - DN 25 with insulation, with equipment	606001
Hydraulic separator CPN 100 2F - DN 32 with insulation, with equipment	617001
Hydraulic separator CPN 100 2F - DN 40 with insulation, with equipment	617002

Hydraulic separator XPN



Hydraulic separator **XPN** are made of steel. They are factory-equipped with insulation, on the upper side with a connection for a vent and a place for mounting the temperature sensor, and on the lower side with a drain connection. The set includes a air vent with a check valve and a drain valve.

Attention!!

Hydraulic separator are intended for vertical mounting only.

Equipment:



Type	Flow [m ³ /h]	Volume [l]	Catalog number
Hydraulic separator XPN 60 - DN 25 with insulation, with equipment	1,80	1,1	611051
Hydraulic separator XPN 60 - DN 32 with insulation, with equipment	2,30	1,6	611052

Hydraulic separator XP

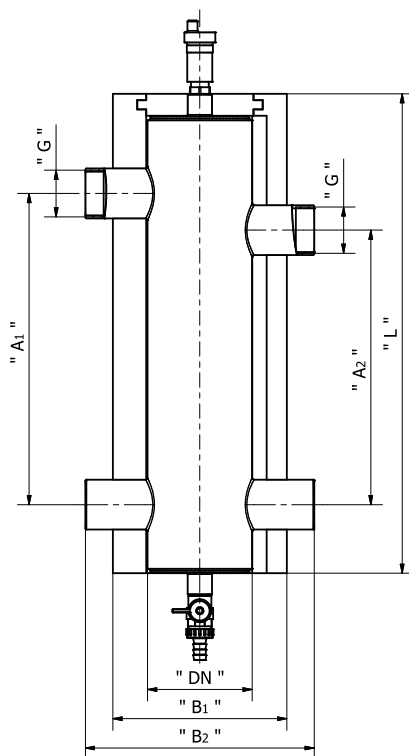
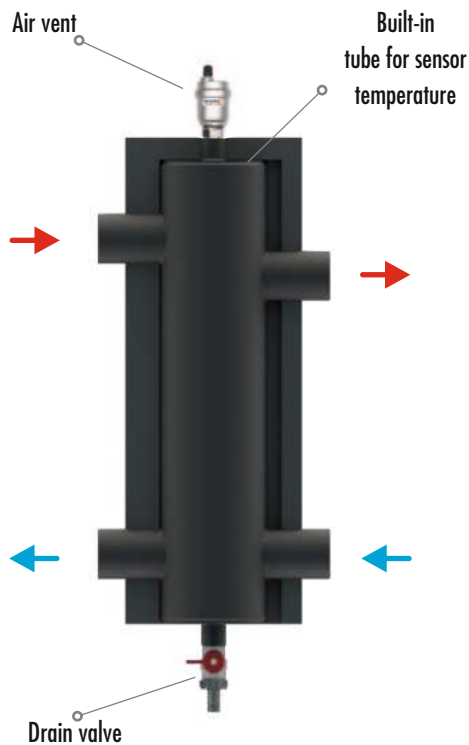

Hydraulic separator **XP** are made of steel. They are factory-equipped with insulation, on the upper side with a connection for a vent and a place for mounting the temperature sensor, and on the lower side with a drain connection. The set includes air vent with check valve and drain valve.

Technical data:

Maximum pressure: 8 bar
 Maximum temperature: 110 °C
 Insulation: EPP black 40 g/l

Attention!!

Hydraulic separators are intended for vertical mounting only.

Equipment:



	XP 65 - DN 25	XP 80 - DN 32	XP 100 - DN 40	XP 150 - DN 50
A ₁ (mm)	300	300	300	350
A ₂ (mm)	340	340	340	440
B ₁ (mm)	155	155	190	250
B ₂ (mm)	200	200	250	300
L (mm)	520	520	520	680
DN	65	80	100	150
G	GW 1"	GW 1 1/4"	GW 1 1/2"	GW 2"

50 kW

80 kW

120 kW

180 kW

Type	Flow [m ³ /h]	Volume [l]	Catalog number
Hydraulic separator XP 65 - DN 25 with insulation, with equipment	2,3	1,6	611081
Hydraulic separator XP 80 - DN 32 with insulation, with equipment	4,2	2,5	611082
Hydraulic separator XP 100 - DN 40 with insulation, with equipment	5,7	3,8	611083
Hydraulic separator XP 150 - DN 50 with insulation, with equipment	9,0	11,2	611084

Pump group with plate heat exchanger BW



Compact pump group BW - DN 25 is equipped with two brass ball valves with supply and return water thermometers, coupler, check valve, plate heat exchanger, safety group 2.5 bar with pressure gauge 0-4 bar, two drain valves, handles wall and insulation.

Technical data:

Max pressure:	8 bar
Max temperature:	120°C
Insulation material:	EPP black 40 g/l
Axle spacing:	125 mm
Gaskets material:	VITON or EPDM
Connections:	1" F
Installation length of pump:	180mm
Number of plates:	20 or 30

Type	Catalog number
Pump grup BW 20 with 20-plates heat exchanger, without pump	606155
Pump grup BW 30 with 30-plates heat exchanger, without pump	606156
Pump grup BW 20 with 20-plates heat exchanger, with pump Wilo Yonos Para 25/6	616157
Pump grup BW 30 with 30-plates heat exchanger, with pump Wilo Yonos Para 25/6	616167
Pump grup BW 20 with 20-plates heat exchanger, with pump Grundfos UPM3S AUTO 25 - 60	616152
Pump grup BW 30 with 30-plates heat exchanger, with pump Grundfos UPM3S AUTO 25 - 60	616162
Pump grup BW 20 with 20-plates heat exchanger, with pump DAB Evosta2 65/180	616158
Pump grup BW 30 with 30-plates heat exchanger, with pump DAB Evosta2 65/180	616168

Wafer butterfly valve with an electric actuator



Technical data of the throttle:

Pressure:	PN 6
Working temperature:	0 ° C to + 120 ° C

Technical data of the actuator:

Supply voltage:	230 VAC
Control:	three-point or close / open
Torque at rated voltage:	20 Nm for SR 230 40 Nm for GR 230

Manual override Gear disengagement button (temporary or permanent release)

Movement time:	90 sec / 90 °
Noise level:	Max.45 dB (A) (without valve)
Position indicator	Mechanical, integrated
Protection class	II (fully insulated)
IP 54	in any mounting position
Ambient temperature range:	0 ... + 50 ° C

Type	Catalog number
Butterfly valve DN 40 with electric actuator SR 230	005203
Butterfly valve DN 50 with electric actuator SR 230	005204
Butterfly valve DN 65 with electric actuator SR 230	005205
Butterfly valve DN 80 with electric actuator SR 230	005206
Butterfly valve DN 100 with electric actuator GR 230	005207
Butterfly valve DN 125 with electric actuator GR 230	005208

Type	Catalog number
Butterfly valve DN 50	005002
Butterfly valve DN 65	005003
Butterfly valve DN 80	005004
Butterfly valve DN 100	005005
Butterfly valve DN 125	005006



womix
Comfort Controls

Poland, Szubin 89-200
Sportowa 31

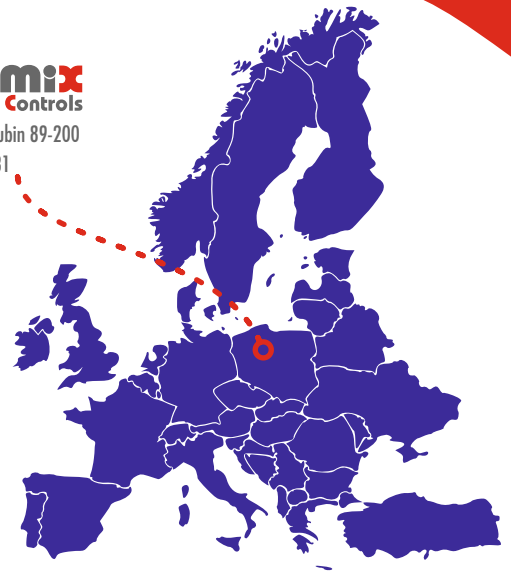

Contact
us:



Michał Górecki
tel. + 48 570 108 498
export@womix.pl

Terms of cooperation

§1. Introduction.

- 1.1. The sales contracts entered into by WOMIX. (hereinafter the „seller”) while conducting its business activities are governed by these general terms and conditions, unless there are exceptions resulting from an explicit written agreement and expressly approved in writing by the Sales Office of the seller.
- 1.2. Any terms and conditions of the buyer and in particular conditions of purchase, will not apply to the relationships between the parties unless expressly accepted in writing and approved in the same form by the Sales Office of the seller: in this case, however, unless waived in writing, these terms and conditions still remain in effect.
- 1.3. The possible invalidity of one or more provisions of these general conditions of sale will not affect the validity of the contract as a whole.
- 1.4. These general conditions of sale are considered to be fully read and accepted by the buyer upon order placement.

§2. Formation of the contract and its execution.

- 2.1. Orders taken or commitments made by representatives, agents or other collaborators of WOMIX cannot bind the seller in any way; it follows that all orders processed by the aforementioned representatives, agents and collaborators become valid and effective only upon written confirmation from the seller and the written approval by the Sales Office of the seller.
- 2.2. Any changes to the order will be effective only upon written confirmation and written approval by the Sales Office of the seller.

§3. Purpose and prices.

- 3.1. The data, measurements, articles, prices, features, performance and all other data shown in our catalogues, price lists, prospectuses, circulars etc. are given only as indications; they may be changed without any warning and are only considered binding for the seller in the event of their explicit mention in the acceptance or confirmation of the order.
- 3.2. The price lists of the seller are not offers; they are only approximate and may be modified unilaterally by the seller without notice.
- 3.3. The prices are considered to be standard, unless otherwise agreed, „ex-works of the seller”, packaging excluded. Fees, taxes and duties in force at the time of delivery are the responsibility of the buyer. Prices do not include services or charges not mentioned.
- 3.4. Insurance expenses for the goods are to be borne by the buyer, as well as any expenses and customs duties due to delays in custom clearance or other reasons.

§4. Payments.

- 4.1. Barring written exceptions, all payments must be made at the offices of WOMIX in Euro.
- 4.2. Payment for the goods is made in the form of a prepayment.
- 4.3. The date of payment shall be the date the influence of the amount indicated on the invoice VAT on the Seller's bank account.

§5. Delivery and transfer of risk.

- 5.1. The seller will notify by letter or telegram or telefax or e-mail or certified mail (certified email address) that the goods are available to the buyer at the seller's premises.
- 5.2. The delivery of material is considered „free on board”. The responsibility of the seller stops with delivery to the buyer or carrier; consequently the material is transported at the risk of the buyer. In cases in which, due to specific buyer interventions, the material is sold „free delivery”, no disputes will be accepted for any thefts, damages or tampering. Any agreements with forwarding agents, including the amount and payment of the cost of transportation are considered settled in the name of and on behalf of the buyer who, from that moment onward, accepts and approves the conduct of the seller.

§6. Transport and packaging.

- 6.1. The cost of transporting material from the seller's premises to the place of destination is normally intended to be borne by the seller, unless otherwise agreed in the order confirmation. Transport costs are, in any case, to be borne by the buyer. The buyer assumes all risks inherent in the transportation starting from the delivery of the goods to the shipper or carrier, even if the right to property is reserved.
- 6.2. The seller will provide the packaging according to the rules of use. The seller is exempt from any liability for loss or damage which does not result from intentional or gross negligence by the seller and is not the direct and immediate consequence of its conduct. For specific types of packaging, the extra amounts indicated in the price list or in the order confirmation will be included in the invoice.
- 6.3. Any transport costs are determined individually, depending on the number, type and weight of the shipment.

§7. Testing and warranty.

- 7.1. Unless otherwise stated, supplies by the seller are regulated by the rules and details contained in the WOMIX catalogue.
- 7.2. All the products of the seller are carefully tested on site; they are therefore covered by a warranty for a period of two from the date of issue of the invoice.
- 7.3. The seller's warranty is limited to pure and simple replacement of the defective part, which must first be returned to the seller (and therefore any expenses, damages, interest or compensation of any kind are strictly excluded from the warranty). In any case, the components produced by the seller recognised as being faulty, preceded by a complaint made by the buyer within the maximum time period set forth by existing regulation, will be replaced only by the seller. Nevertheless the liability of the seller is limited to faults which appear under normal working conditions and during correct product use.
- 7.4. Any damage caused by incorrect product operation must be made known within 24 hours, providing the name of the damaged part and the approximate amount of the damage. Subsequently photographs showing the damage must be sent, together with the product which caused the alleged damage, for examination in the laboratory. Anything which may provide evidence of the extent of the damage must be made available to the seller until the case is closed.
- 7.5. The seller refuses all responsibility for any damage or injury to persons, animals or property derived from the use of the appliances without observing the safety provisions or from appliances which are not installed correctly and/or were installed without performing the appropriate operation checks.

§8. Terms of delivery and return of goods.

- 8.1. The terms of delivery go into effect on the day following that on which the agreement is reached on each element of the contract and all information necessary for execution is received by the seller. In any case it is understood that the terms of delivery specified in the seller's offers only serve as guidelines and are not binding.
- 8.2. If an import licence is requested from the country of the buyer, the delivery terms will go into effect from the moment the seller has been informed in writing of the granting of the licence.
- 8.3. The seller assumes no responsibility for any delays in delivery. Deliveries of goods, even if partial, cannot be refused by the buyer; partial deliveries of goods do not give the buyer the right to cancel the order.
- 8.4. No liability will be due to the seller, and therefore nothing will be due to the buyer, if the delay is not attributable to the seller - as in the case of delays by third parties, including suppliers and subcontractors, due to force majeure such as demonstrations, riots, strikes or lockouts, wars, epidemics, closure, accidents or failures of machinery or tools, fires, collapses, floods, earthquakes, extreme temperatures, weather events and generally in any other case involving partial or total inactivity of the premises of the seller and production stoppage or slowdown.
- 8.5. In any case, the buyer cannot use the delay in delivery to terminate the contract.
- 8.6. Except as provided for in number 8. on the subject of warranty, the client cannot for any reason return delivered material without the express written permission of the seller. To obtain consent for return and be entitled to a refund of the purchase price already paid, the buyer must return the material as follows:
 - the material must be unused and returned in the same condition in which the buyer received it;
 - the material must be returned within fifteen days (15) of the date of the invoice;
 - the material must be returned to WOMIX - at the expense and risk of the buyer - to the headquarter in Poland, 89-200 Szubin ul. Sportowa 31

§9. Withdrawal and suspension of supply.

- 9.1. In case of unforeseen circumstances, force majeure and fortuitous events (such as but not limited to strikes or lockouts, missed or reduced supply of raw materials, difficulty of transport, wars, insurrection, interruption of communications, however caused, plant breakdowns etc.) the seller has the right to withdraw from this agreement and/or suspend the current supply when these unexpected events, wherever they take place, substantially alter the state of the markets, the value of money, Polish industry conditions or circumstances arise, even endogenous, that according to the incontestable judgement of the Seller, do not allow for the useful continuation of the supply relationship.

- 9.2. In any case, under these general conditions of sale regarding withdrawal from the contract and/or suspension of the supply of material, the buyer will not be entitled to reparation, compensation, reimbursement or damages.

§10. Intellectual property rights.

- Any drawing or technical document related to products of the seller, even if given to the buyer, remains the exclusive property of the seller and cannot be used by the buyer or copied, reproduced, transmitted or communicated to third parties without the prior written authorisation of the seller.

§11. Complaints.

- 11.1. The buyer is required to examine the goods carefully when it receives delivery and notify the seller within five (5) days from the delivery/receipt, of any defects or quality issues found in the product.
- 11.2. Any complaints and/or disputes about defects or quality issues of the product do not give the buyer the right to omit or delay payments of the supply.



Womix Comfort Controls

Configurator of pump groups systems

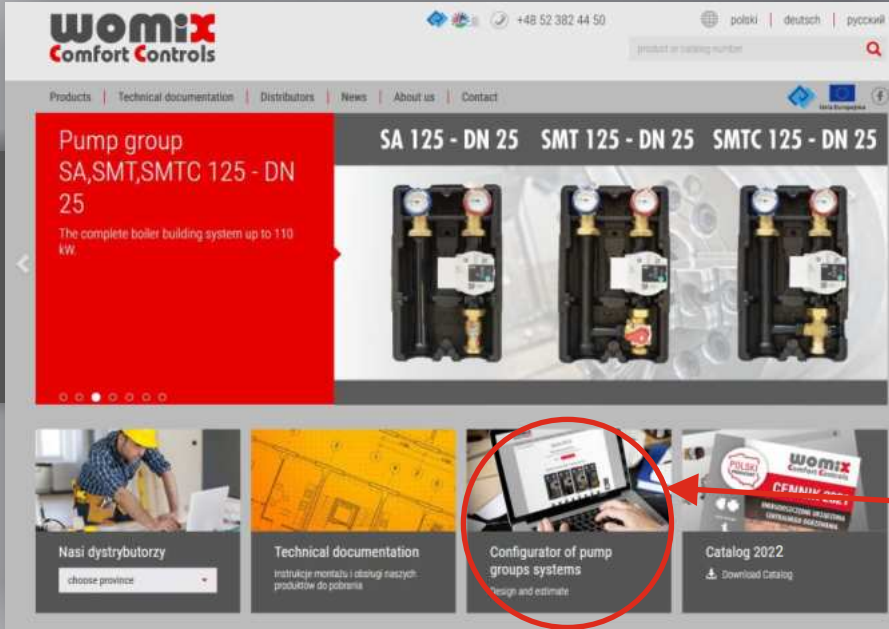

Check on
Facebook



Check
our products on



www.womix.pl/en

Device selection has never been so easy

search the website
www.womix.pl/en

CHECK →

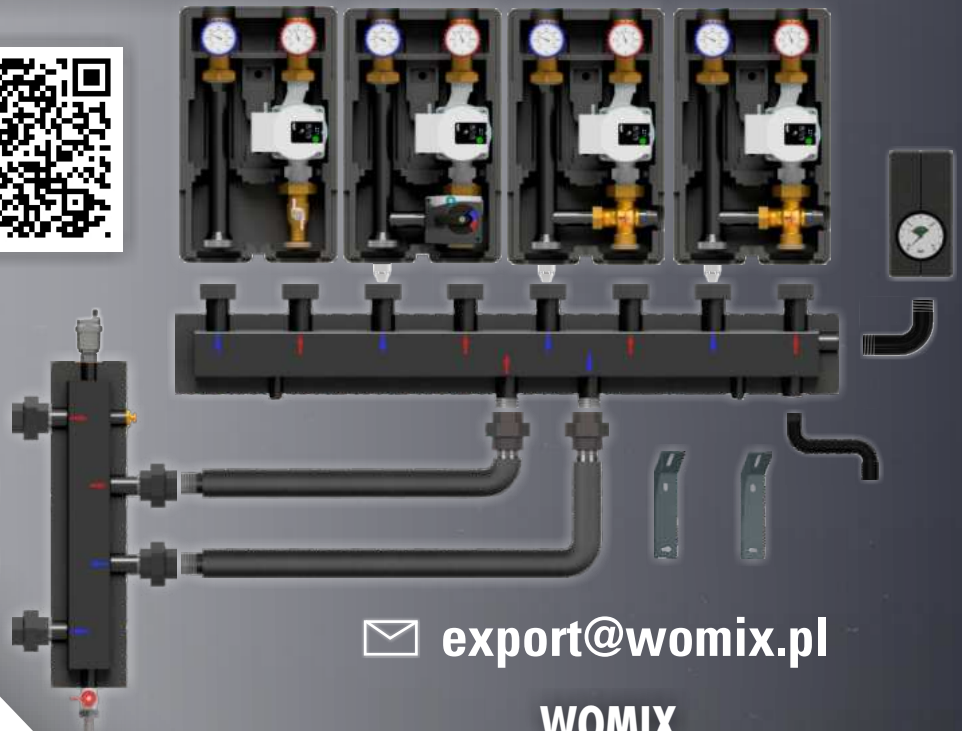

✉ export@womix.pl

WOMIX
Sportowa 31 89-200 Szubin
tel. +48 52 382 44 50
mobile: +48 570 108 498

 www.facebook.com/WomixPolska/

www.womix.pl

Womix is not responsible for mistakes, which may be in this catalog. Womix reserved the right to change technical parameters of products. Product images may differ from actual.